



The Windows™ Laser Printer-Designed for Speed

WinType 4000

Users Manual

Safety Notice

This printer is certified as a Class 1 laser product under the U.S. Department of Health and Human Services (DHHS) Radiation Performance Standard according to the Radiation Control for Health and Safety Act of 1968. This means that the printer does not emit hazardous laser radiation.

Since radiation emitted inside the printer is completely confined within protective housings and external covers, the laser beam cannot escape from the machine during any phase of user operation.

The Center for Devices and Radiological Health (CDRH) of the U.S. Food and Drug Administration implemented regulations for laser products on August 1, 1976. These regulations apply to laser products marketed in the United States. The label on the printer indicates compliance with the CDRH regulations and must be attached to laser products marketed in the United States.

Caution-use of controls or adjustments or performance of procedures other than those specified herein may result in hazardous radiation exposure.

Federal Communications Commission Radio Frequency Interference Statement

This equipment has been tested and found to comply with the limits for a Class B digital device, pursuant to Part 15 of FCC rules. These limits are designed to provide reasonable protection against harmful interference in a residential installation. This equipment generates, uses and can radiate radio frequency energy and, if not installed and used in accordance with the instructions, may cause harmful interference to radio communications. However, there is no guarantee that interference will not occur in a particular installation. If this equipment does cause harmful interference to radio or television reception, which can be determined by turning the equipment off and on, the user is encouraged to try to correct the interference by one or more of the following measures.

- Reorient or relocate the receiving antenna.
- Increase the separation between the equipment and receiver.
- Connect the equipment into an outlet on a circuit different from that to which the receiver is connected.
- Consult the dealer or an experienced radio/TV technician for help.

Unauthorized modifications of this product by the user will void his authority to operate the equipment unless expressly approved by the party responsible for compliance.

For compliance with the Federal Noise Interference Standard, this equipment requires a shielded cable.

The above statement applies only to printers marketed in the U.S.A.

Statement of The Canadian Department of Communications Radio Interference Regulations

This digital device does not exceed the Class B limits for radio noise emissions from digital apparatus set out in the Radio Interference Regulations of the Canadian Department of Communications.

Le présent appareil numérique n'émet pas de bruits radioélectriques dépassant les limites applicables aux appareils numériques de la classe B prescrites dans le Règlement sur le brouillage radioélectrique édicté par le ministre des Communications du Canada.

The above statement applies only to printers marketed in Canada.

Safety Notices for Finland

Tämä Kirjoitin LUOKAN 1 LASERLAITE.

VAROITUS! Laitteen käyttäminen muulla kuin tässä käyttöohjeessa mainitulla tavalla saattaa altistaa käyttäjän turvallisuusluokan 1 ylittävälle näkymättömälle lasersäteilylle.

DENNA SKRIVARE ÄR EN KLASS 1 LASERAPPARAT.

WARNING! Om apparaten används på annat sätt än i denna bruksanvisning specificerats, kan användaren utsättas för osynlig laserstrålning, som överskrider gränsen för laseklass 1.

The above statement applies only to printers marketed in Finland.

Bescheinigung des Importeurs

Hiermit wird bescheinigt, daß der

COMPUTER DRUCKER LX04GDI

in Übereinstimmung mit den Bestimmungen der

VDE 0878 3/22.89, EN 55022: 1987, BMPT Vfg. 243/1991 und 46/1992

funk-entstört ist.

Dem Zentralamt für Zulassungen im Femmeldewesen wurde das Inverkehrbringen dieses Gerätes angezeigt und die Berechtigung zur Überprüfung der Serie auf die Einhaltung der Bestimmungen eingeräumt.

Star Micronics Deutschland, GmbH

Westerbachstraße 59, D-60489

Frankfurt, Germany

The above statements apply only to printers marketed in Germany.

Trademark Acknowledgments

HPLaserJet IIP, PCL4: Hewlett Packard Company

PostScript, Adobe Type Manager: Adobe Systems, Inc.

LaserWriter NTX, TrueType: Apple Computer, Inc.

Intellifont: Agfa Corporation

Windows 3.1, MS-DOS: Microsoft Corporation

Xerox 4024: Xerox Corporation

EET: Destiny Technology

Notice

- All rights reserved. Reproduction of any part of this manual in any form whatsoever without STAR's express permission is forbidden.
- The contents of this manual are subject to change without notice.
All efforts have been made to ensure the accuracy of the contents of this manual at the time of press. However, should any errors be detected, STAR would greatly appreciate being informed of them.
- The above notwithstanding, STAR can assume no responsibility for any errors in this manual.

©Copyright 1994 Star Micronics Co., Ltd.

©Copyright, WinRefs 1993-1994, Destiny Technology Corp. Ver. 1.0

©Copyright, WinStyler™ 1992-1994, Destiny Technology Corp. Ver. 1.00

©Copyright, DT1R™ 1992-1994, Destiny Technology Corp. Ver. 1.0

©Copyright, LaserAct® 1990-1994, Destiny Technology Corp. Ver. 4.5

©Copyright, PageStyler® 1989-1994, Destiny Technology Corp. Ver. 1.0

©Copyright, 1992, Microsoft Corporation

Contents

Introduction	v
A word about the printer	v
System requirements	v
How to use this manual	vii
Features of the printer	vii
Printer components	viii
Chapter 1 Setting up your printer	1
Unpacking and checking the package contents	1
Package contents	1
Placing the printer	1
Installing the toner cartridge	2
Setting up the upper paper tray	4
Setting up the output tray	5
Connecting the printer to the computer	5
Connecting the power cord	6
Turning the printer ON	6
Turning the printer OFF	6
Relocating the printer	7
Chapter 2 Selecting print media	11
Recommended print media	11
Printing media to avoid	12
Loading plain paper, OHP (overhead projection) film and label sheets	12
Loading envelopes	15
Chapter 3 Installing the printer driver and TrueType fonts	17
System requirements	17
Printer command languages	18
Installing the printer driver and TrueType fonts	20
Removing the printer driver software	24
Chapter 4 Printing with WinType 4000	25
Windows Direct (GDI) mode	25
PostScript mode	25
PCL mode	25
Features of the printer driver software	26

Printing with the Windows Direct (GDI) mode	26
Manual duplex printing	29
Duplex printing errors	30
Using fonts in the Windows Direct (GDI) mode	30
Eliminating screen fonts from your application	31
Printing with the PostScript mode	32
Printing from a Windows application	32
Fonts in PostScript Mode	33
Printing DOS applications in PostScript mode under Windows	35
• DOS Prompt Method	35
• .PIF File Method	35
Printing with the PCL mode	36
Printing in PCL mode from a Windows application	36
Printing DOS applications in PCL mode under Windows	37
Fonts in PCL Mode	39
Recovering from an error message in PCL or PostScript modes when	
running a DOS application from within Windows	40
Saving download fonts and macros in the PCL mode	41
Chapter 5 The Star WinType Print Manager	43
Enabling the WinType Print Manager	43
Viewing and accessing the WinType Print Manager	45
Options:	46
Size	48
Queue information	49
Display of information	49
Changing priority in the queue	50
Status Bar	50
Progress Bar	50
Pause	50
Resume	50
Add	51
Delete	51
Printing to a file in the Windows Direct (GDI) and PCL modes	51

Printing to an Encapsulated PostScript file in the PostScript mode	54
Quitting the Star WinType Print Manager	55
Exiting before a print job has been completed	55
Chapter 6 Star WinType Printer Status Display	57
Selecting the Printer Status Display - Windows Direct (GDI) mode	57
Selecting the Printer Status Display - PCL and PostScript modes	59
Accessing and viewing the Star WinType 4000 Printer Status Display	60
Options:	61
Help:	62
Power Off or Cable Problem	63
Pause	64
Resume	64
Delete	64
Chapter 7 Maintenance & troubleshooting	65
Maintaining your printer	65
Handling of the toner cartridge	65
Cleaning your printer	66
Cleaning the output port window	66
Clearing paper jams	67
Troubleshooting: Solving print quality problems	70
Other mechanical problems	74
The front door will not shut	74
The Error LED indicator is lit and the printer will not print	74
Chapter 8 Reference information	75
Specifications	75
Character tables for PCL mode	79
Glossary	82
Index	86

Introduction

Thank you for purchasing the Star WinType 4000 Laser Printer. This Users Manual has been organized into eight chapters, a glossary and an index to help you learn the proper operation and care of your printer. The first six chapters explain the basic care and handling of this printer and the operation of the printer driver software. The remaining chapters are intended as a reference guide for troubleshooting any printing problems you may encounter.

A word about the printer

The Star WinType 4000 is a new laser printer that has been developed specifically for users of Windows™ version 3.1. This printer is provided with the WinType software and does not require special add-in cards or cartridges. The WinType 4000 differs from other printers in that it is directly driven by the computer's CPU; hence it has faster response and better status information. In addition, by expanding the memory of your computer, or by upgrading to a more powerful PC, the performance of your printer will also improve.

This printer supports three printing modes: Windows Direct (GDI), PostScript and PCL. The Windows Direct (GDI) mode offers the full performance of the total printing system while PCL mode offers compatibility with HP LaserJet IIP software drivers. PostScript mode lets you print graphics intensive files with ease.

Your computer and the WinType 4000 communicate bi-directionally to exchange information on the operating status of the printer. Your computer will display status information such as paper out, or paper jams via Print Status Window. The WinType 4000 printer driver eliminates the need for a complex printer control panel.

System requirements

To operate this printer you need an IBM compatible PC with at least a 386SX 16-MHz CPU. The PC must be running DOS 3.3 or later and Windows 3.1 in Enhanced Mode. A Microsoft-compatible mouse is highly recommended. The printer requires at least 4 megabytes (MB) of PC memory (RAM) which is also the minimum amount of memory recommended by Microsoft Corporation for use with Windows version 3.1.

This printer driver software requires approximately 1.4 megabytes of disk space on your system's hard drive. Up to approximately 8.5 megabytes of disk space is required for permanent virtual memory under Windows. If you have more than 4 megabytes of RAM, you won't need the entire 8.5 MB of virtual memory, which is described later in Chapter 3.

This printer requires a total of 12.5 megabytes of disk space, which is divided between your computer's RAM memory (which needs to be at least 4 MB) and Windows virtual memory. If your system has 4 MB of RAM, then you must allocate at least 8.5 MB of virtual memory in Windows. If you have 5 MB of RAM, then you need at least 7.5 MB of virtual memory, etc.

A standard PC parallel printer port is required to connect the printer using a standard Centronics parallel cable.

This users manual

Chapter 1 Setting up your printer

This chapter explains the basic procedures for unpacking, placing and connecting your printer.

Chapter 2 Selecting print media

This chapter provides information on the proper print media to use with this printer. It also includes instructions on loading paper.

Chapter 3 Installing the printer driver software and TrueType fonts

This chapter details the procedures used to install the WinType printer driver software and TrueType fonts. You must install the printer driver software to be able to print with this printer.

Chapter 4 Printing

This chapter will take you through each of the three printing modes and explain the meaning and usage of each mode.

Chapter 5 Print manager

This chapter will tell you about this useful feature which allows you to control the printing of your documents.

Chapter 6 Print status window

This chapter explains the usage of the print status window which provides you with helpful information on the printer's operation.

Chapter 7 Maintenance & troubleshooting

This chapter explains the proper procedures for routine maintenance and care of your printer and a quick reference to help you solve any problems which may occur.

Chapter 8 Reference information

This chapter lists the printer's specifications. It also contains PCL4 character tables.

Glossary

This provides you with definitions of commonly used terms.

Index

This lists, in alphabetical order, terms which appear in this manual.

How to use this manual

Each chapter provides you with simple explanations of the printer's operation. We have included illustrations of the printer and screens wherever necessary and where space allowed. You should be able to operate this printer by carefully following each of the steps provided.

Features of the printer

This printer is capable of many useful and high quality printing functions ranging from printing on plain copier paper to OHP (overhead projection) film and label sheet printing.

The main features of the printer include:

- Ultra fast, Windows Direct (GDI) printing
- True WYSIWYG performance in Windows
- PostScript compatibility for both Windows and MS-DOS applications running under Windows
- PCL 4 compatibility for both Windows and MS-DOS applications running under Windows
- High speed bidirectional interface for easy to understand feedback on the computer screen about the printer's operation
- 35 TrueType fonts for Windows 3.1 applications and 14 bitmapped fonts for DOS applications and fully compatible with 13 PostScript Type 1 fonts
- Edge Enhancement Technology (EET) for 600 dpi class output
- Energy Star compliant - Sleep Mode
- Toner Save Mode - Increases toner yield up to twice the normal consumption levels
- Manual Duplexing for double-sided printing
- Single unit EP toner cartridge with high definition toner.
- Compact size - Small footprint

Printer components

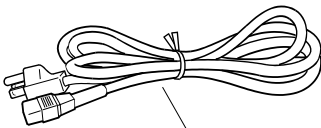
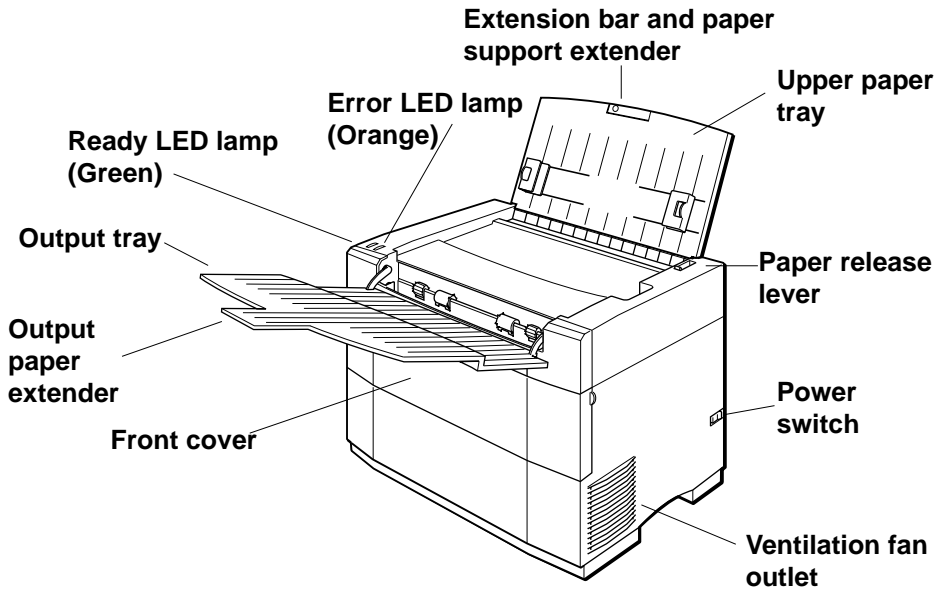

Power cord

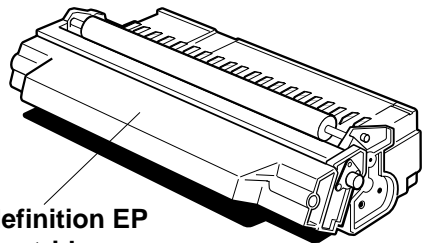

High definition EP toner cartridge

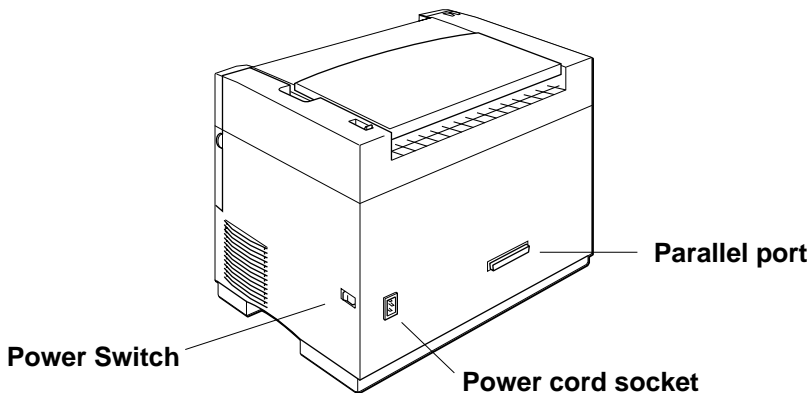

Chapter 1 Setting up your printer

Your printer is a reliable and quality precisioned instrument. It is every owner's responsibility to make sure that their equipment is properly placed and sensibly used. If the following conditions are met, you can expect your printer to perform at its finest and to last a long time.

Unpacking and checking the package contents

When you open the box, you will find the items in the list below included. Remove all of the packing materials. Check to make sure, when removing the contents of the carton, that each item has been included. There should be a total of five items. If you are missing any of them, contact your dealer immediately.

Package contents

- 1 WinType 4000 laser printer
- 2 This Users Manual
- 3 Power cable
- 4 Printer driver and font software (3 disks)
- 5 Starter high definition EP toner cartridge

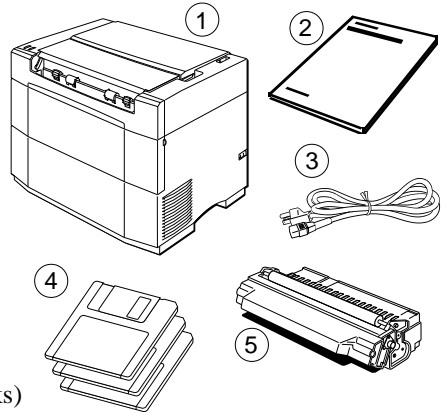

We strongly recommend that you save the box and all of the packing materials for this printer. They will protect the printer should you ever need to transport it to a new location.

Caution: Always remove the EP toner cartridge prior to transporting this printer. Failure to do so may result in permanent damage to your printer and may void your warranty.

Placing the printer

If you take good care of your printer, you can expect it to perform at its finest and to last for a very long time. You can do that by first setting your printer in an area which meets the following requirements.

- A firm, level surface which is free from vibration.
- An area free from excessive heat such as direct sunlight or heaters.
- A dust free environment.
- A steady power supply. Do not connect it to an outlet which uses the same circuit as a refrigerator or an air conditioner.
- Use only the line voltage specified on the identification plate.

- The printer should be positioned relatively close to the computer. The maximum recommended length of the parallel interface cable (not supplied) is 2 meters or 6 feet.
- The printer should be placed so that there is a minimum of 50mm (2 in.) clearance on all sides to prevent blockage of its ventilation fan outlets.

Installing the toner cartridge

After selecting a suitable place for your printer, you can begin preparing it for printing. Always follow these easy steps to install the EP (electrophotographic) toner cartridge. The toner cartridge contains toner (a dry ink substance) and an EP (electrophotographic) drum that transfers the toner to the paper.

Steps:

1. Face the front of the printer and gently open the front cover of the printer using both hands.

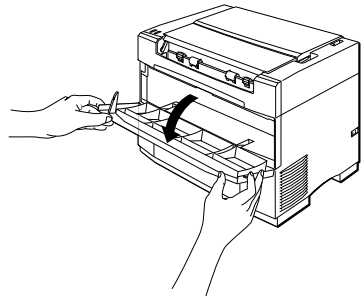

Caution: Never lean on or rest heavy objects on the open cover of the printer.

2. After unpacking the toner cartridge, turn it over and remove the two strips of tape and the protective shim. Next, gently remove the cardboard pad.

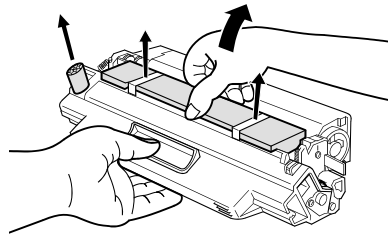

3. Turn the toner cartridge rightside-up and gently rock it back and forth seven or eight times to free the toner.

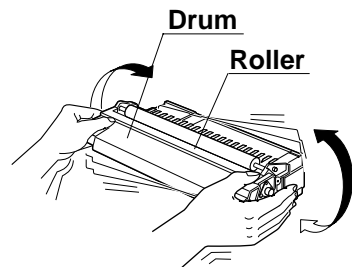

Caution: Be careful when holding the cartridge not to touch the roller, drum or top of the cartridge.

Note: Save the toner cartridge package in case you need to store the cartridge after removing it. Do not expose the toner cartridge to direct sunlight or strong room lighting. Complete the installation process for the toner cartridge as quickly as possible to avoid damage to the cartridge.

Always use these steps when you install a toner cartridge.

4. Lay the cartridge on a flat surface and press down with one hand. Grasp the end tab of the sealing tape and pull the tape straight out horizontally from the cartridge.

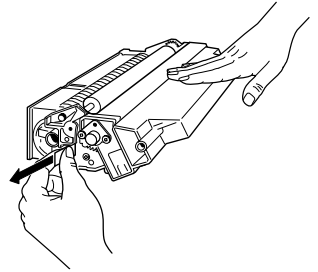

Note: Pull gently outward from the cartridge because pulling up on the tape may break it.

Caution: Make certain that the cartridge is flat to prevent damage to the cartridge roller or the drum.

5. Grasp the toner cartridge by its molded center grip and insert the cartridge into the front of the printer. Make certain that the locking knobs on either side of the cartridge rest on the guides inside the printer.

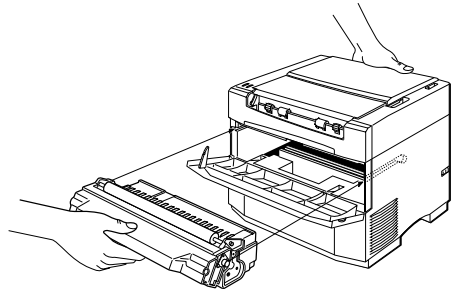

6. While keeping the cartridge level, slide the cartridge into the printer until it stops well inside the body of the printer.

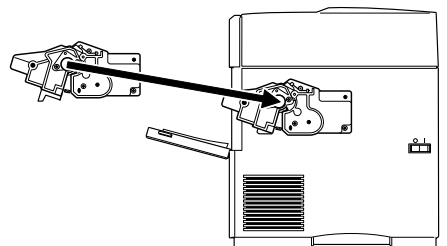

7. Press the toner cartridge firmly into the printer until it locks into position.

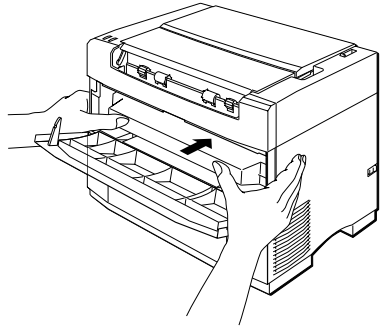

8. Close the front cover by pressing at the top corners. The door will lock closed.

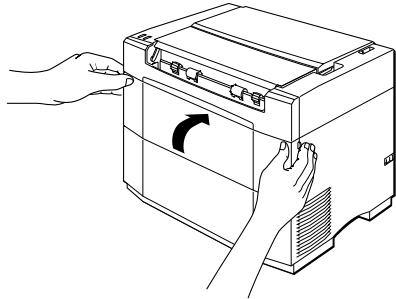

Caution: If you experience a paper jam, never pull the paper out of the toner cartridge in the reverse direction of the paper feed mechanism. See page 67 for details on clearing paper jams.

Note: **Always** use these steps when you install a toner cartridge.

Setting up the upper paper tray

Your printer is equipped with a convenient fold-out upper paper tray on the top of the printer body. You can stack up to 100 sheets of 20 lb. paper for continuous multiple page document printing.

Steps:

1. Lift the upper paper tray into the upright position.
2. Lift up on the extension bar until it reaches the desired height.
3. Rotate the paper support extender to its open position.
4. Slide the paper guides to the furthest outside positions.

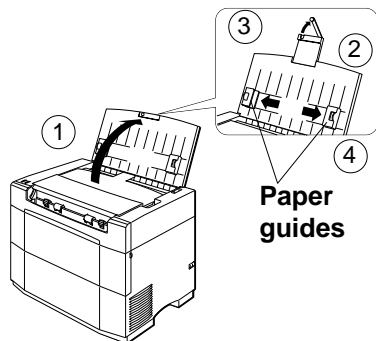

Setting up the output tray

When you print documents, this tray will keep your work in order.

Steps:

1. Lift the output tray to its open position.
2. Slide the output paper extender to its open position.

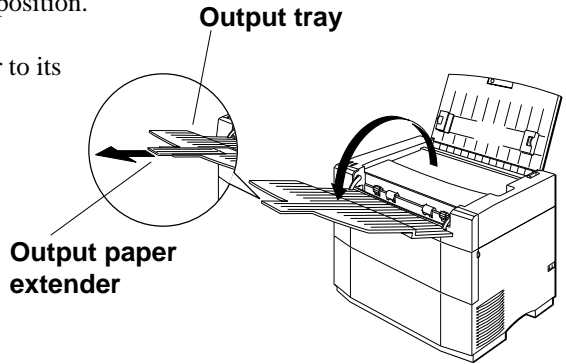

Note: You do not need to open the output tray when printing only one sheet. The output tray will support up to 50 sheets of 20 lb. paper.

Caution: Never lean or rest heavy objects on the open output tray.

Connecting the printer to the computer

Follow these steps to connect the printer to a computer with a high quality 36 pin shielded Centronics parallel interface cable (not supplied).

Steps:

1. Plug one end of the parallel cable into one of the interface ports on the computer.
2. Plug the other end of the interface cable into the printer's interface port which is located on the back of the printer.
3. Securely fit the prongs on either side of the printer's port into the clips on both sides of the printer cable.

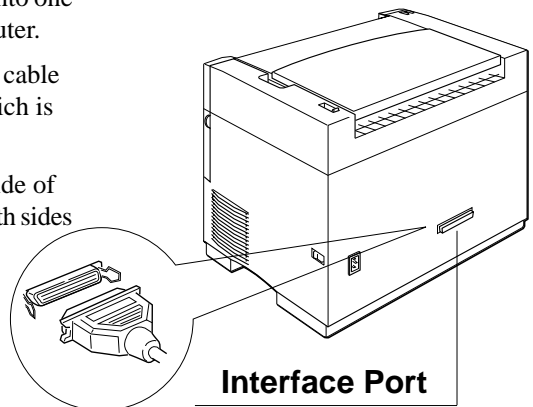

Note: To ensure proper operation, you must use a high quality Centronics-compatible shielded parallel interface cable. This cable should not be longer than 2 meters or 6 feet.

Connecting the power cord

Steps:

1. Make sure that the power switch, located on the side of the printer, is in the OFF [○] position.
2. Securely plug the power cord into the socket located on the rear of the printer.
3. Plug the other end of the power cord into a grounded wall outlet.

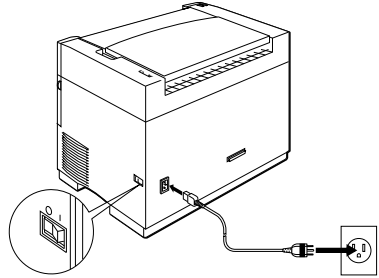

Turning the printer ON

Step:

1. After plugging in the printer's power cord, press the power switch, located on the side of the printer, to the ON [|] position. The Ready LED lamp will flash while the printer is warming up. When the printer is ready to print, it will remain lit.

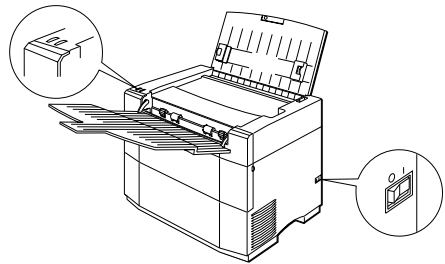

Turning the printer OFF

Step:

1. Pressing the power switch, located on the side of the printer, to the OFF [○] position will turn the printer OFF.

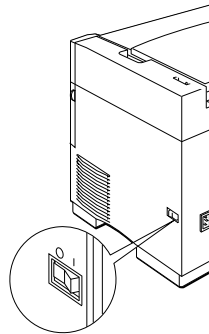

Note: If you are not going to use the printer for an extended period, remove all print media from the upper paper and output trays and close them.

Caution: Never turn the printer OFF while a print job is being processed. If you turn the power OFF accidentally during printing, remove all print media from the upper paper tray. Clear any paper jams that may be inside the printer (see page 67). Then turn the power ON again.

Relocating the printer

Caution: Always follow these steps when moving the printer. You must always remove the toner cartridge when moving the printer. Failure to do so may cause permanent damage to the printer.

Steps:

1. Make sure that the power switch, located on the side of the printer, is in the OFF [O] position.
2. Disconnect the power cord from the wall outlet and the printer socket at the back of the printer. In addition, you should disconnect the parallel cable connecting your printer to your computer.
3. Remove any printed material from the output tray.

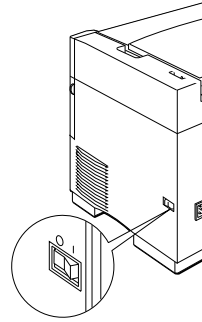

4. Move the paper release lever to the release position (toward the front of the printer) and remove any paper from the upper paper tray.

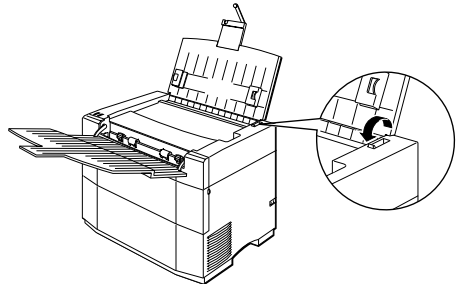

5. Retract and close the output tray and retract and close the upper paper tray. To close the trays, follow the steps shown in the illustration at the right.

1. Push in the output paper extender.
2. Fold up the output paper tray.
3. Close the paper support extenders.
4. Fold down the upper paper tray.

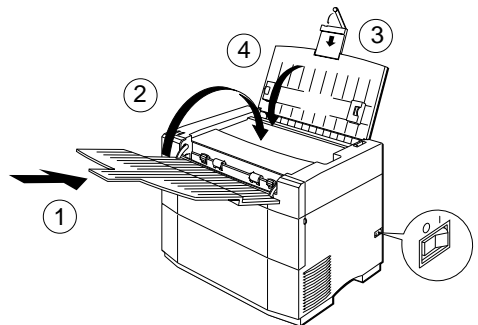

6. Face the front of the printer and open the front cover.

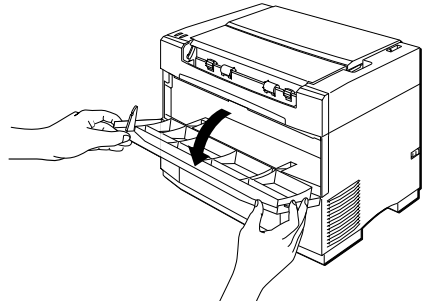

Caution: Never lean or rest heavy objects on the open door.

7. Gently rest one hand on the top of the printer and grasp the toner cartridge by its molded center grip with the other hand and pull upward until the cartridge unlocks and releases.

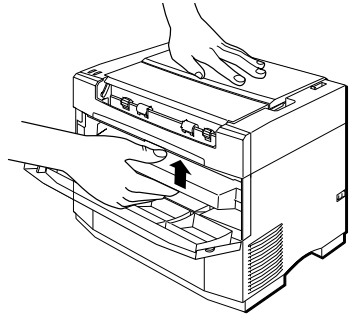

Warning: The fuser area is located in the upper front part of the printer and it is extremely hot. Be especially careful not to touch any part of the fuser area to prevent burns.

The fuser area is extremely hot. Do not touch this area.

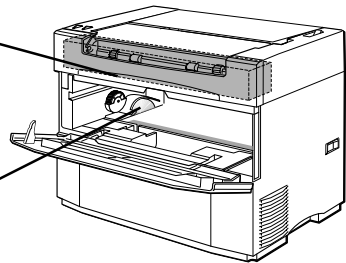

The drive motor is extremely hot. Do not touch.

Warning: The drive motor becomes very hot after extended periods of printing. Be careful not to touch any metal part of the drive motor.

Caution: Do not press too hard on the top of the printer because this could damage the cover or trays.

8. Rotate the toner cartridge slightly downward until it is level. Slide it out from the printer.

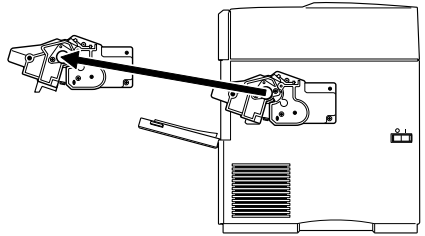

Note: The toner cartridge will not slide smoothly unless it is level.

9. Put the toner cartridge in its original package (aluminum bag) or wrap it in thick cloth to protect it from damage.

Caution: To prevent spilling the toner, do not shake the toner cartridge. Do not expose the cartridge to direct sunlight or strong room light.

10. Close the front cover by pressing on the top corners with your hands. The door will lock closed.

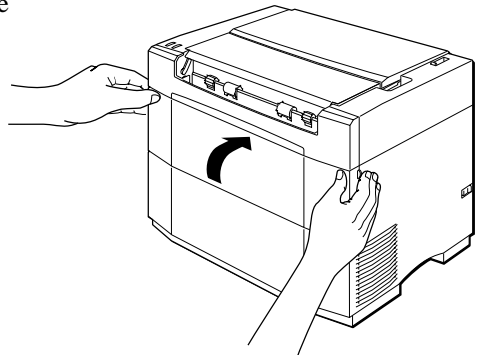

11. Face the back of the printer, tilt the printer toward you and grasp it by the bottom grips on both sides of the body. Carry the printer to the new location.

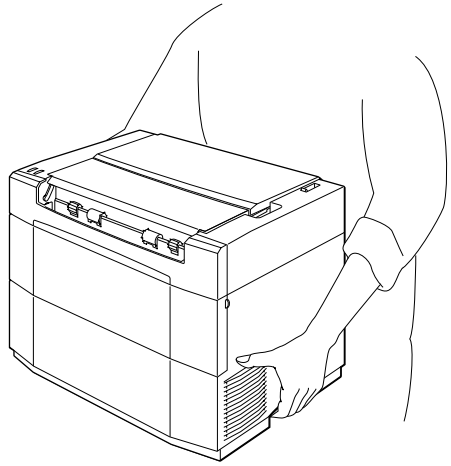

Note: Without paper and the toner cartridge, the printer weighs approximately 6.5 kg. (14.3 lbs.).

Caution: Be sure to locate your printer according to the guidelines explained on page 1, "Placing the printer."

Chapter 2 Selecting print media

Your printer can handle a wide variety of print media including plain paper sizes from Legal and Executive to B5. It can also print on OHP (overhead projection) film, label sheets and envelopes. However, to get the best results in printing quality and printer performance, you should select only the types described here.

Recommended print media

We recommend that you use only high quality paper designed for laser printers or other electrophotographic devices with this printer. Please refer to the following list to determine the types and size of paper you can use.

Type	Size	Weight/Recommended
Plain paper	A4 (8.27" X 11.69") (210mm X 297mm)	60g/m ² to 135 g/m ² (16 lb. to 36 lb.) XEROX 4024
	Letter (8 1/2" X 11") (216mm X 279mm)	
	B5 (7.17" X 10.12") (182mm X 257mm)	
	Executive (7 1/4" X 10 1/2") (184mm X 267mm)	
	Legal (8 1/2" X 14") (216mm X 356mm)	
	A5 (5.83" X 8.27") (148mm X 210mm)	
	A5 (5.83" X 8.27") (148mm X 210mm)	
Envelope	Com-10 (4 1/8" X 9 1/2") (105mm X 241mm)	60 g/m ² to 135 g/m ² (16 lb. to 36 lb.)
	MONARCH (3 7/8" X 7 1/2") (98.5mm X 199mm)	
	DL (4.33" X 8.66") (110mm X 220mm)	
	C5 (6.38" X 9.02") (162mm X 229mm)	
	C5 (6.38" X 9.02") (162mm X 229mm)	
Label sheets	A4 (8.27" X 11.69") (210mm X 297mm)	XEROX, P/N 3R97408
	Letter (8 1/2" X 11") (216mm X 280mm)	XEROX, P/N 3R4469
OHP Film (Overhead Projection)	A4 (8.27" X 11.69") (210mm X 297mm)	XEROX, P/N 3R91330
	Letter (8 1/2" X 11") (216m X 280mm)	XEROX, P/N 3R2780

Printing media to avoid

This laser printer is a sophisticated printing tool and should be used with care. As with any precision instrument, there are proper and improper methods of use. The following table lists the printing media you should avoid when using with this printer.

- Excessively thick or thin media
- Media which has been already laser printed or photocopied
- Wrinkled, curled, torn or bent media
- Punched or perforated media
- Moist or damp media
- Sticky media or media which has adhesive
- Thermal paper
- Coated media
- Carbon paper
- Media unable to withstand temperatures of 150°C. (302°F)
- Stapled or clipped media
- Media which is not recommended for laser printers or electrophotographic devices
- Labels with exposed backing

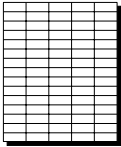

Acceptable

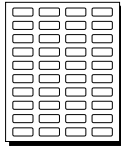

Not Acceptable

In order to maintain high quality printing, we recommend that all printing media is stored until needed. The following are the guidelines for storing your materials.

- Store print media on a flat surface so that it does not bend or curl
- Wrap all unused printing media securely
- Do not unwrap media until ready to use
- Do not expose media to direct sunlight or high humidity for long periods

Loading plain paper, OHP (overhead projection) film and label sheets

You can load up to 100 sheets of plain paper (20 lbs.) or 30 sheets of OHP (overhead projection) film or 30 label sheets in the upper paper tray.

Steps:

1. Move the paper release lever to the front of the printer.
2. Remove any paper that is in the upper paper tray.

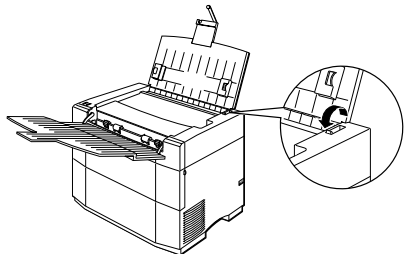

- Adjust the paper guides so that they are slightly wider than the medium on which to be printed.

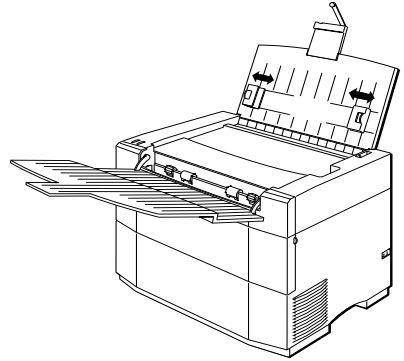

- Fan a stack of print media. This will help prevent paper jams.

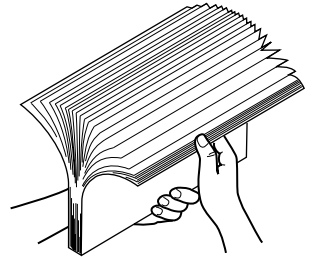

- Load the print media into the upper paper tray with the surface that you want to print on facing the rear of the printer.

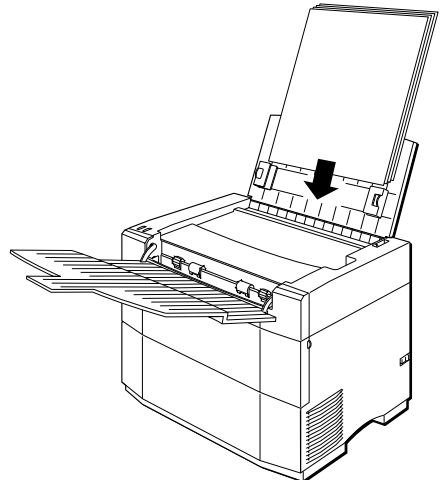

Caution: Only use the paper, labels or OHP film recommended for laser printers to avoid paper jams or quality problems. Do not load more paper, labels or OHP film than the recommended amount because this will cause paper jams.

- Adjust the paper guides to the width of the stack.

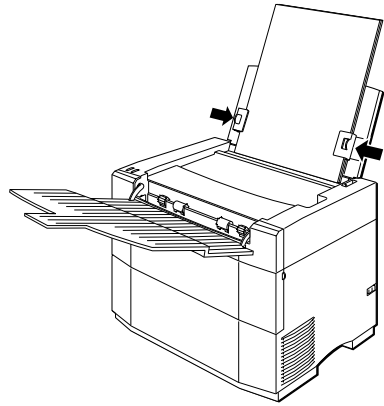

Note: Do not crush the stack with the paper guides.

Caution: The paper should fit completely within the channels of the paper guides.

- Move the paper release lever to the back of the printer.

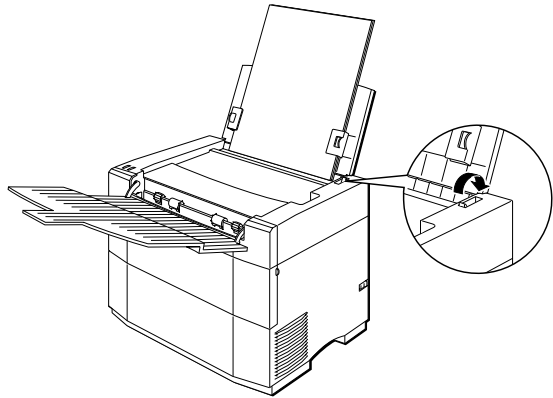

Note: Moving the paper release lever will press the paper against the upper paper tray. When loading a new stack of paper, remove the finished documents from the output tray. Never add more paper to a partially finished stack. Wait until the entire stack has been printed and then load another stack.

Caution: Always make sure that the paper release lever is moved to the back of the printer when printing. If it is not, a print error will occur.

Loading envelopes

You can load up to 10 envelopes in the upper paper tray. Just as with plain paper printing, always put your media with the side to be printed on facing the rear of the printer in the upper paper tray.

Steps:

1. Move the paper release lever to the front of the printer.
2. Remove any paper that is in the upper paper tray.
3. Adjust the paper guides so that they are slightly wider than the medium you are going to be printing on.

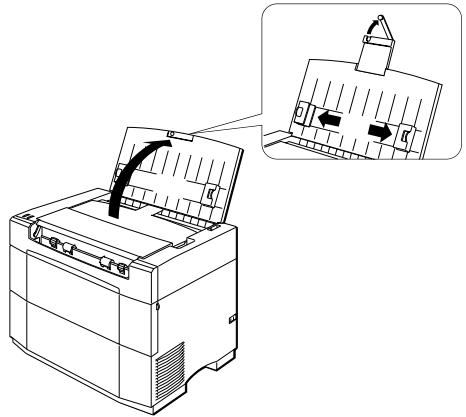
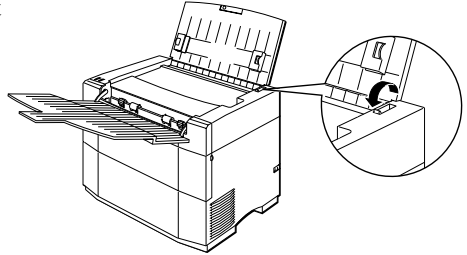

4. Fan the envelopes before loading them into the upper paper tray. This will help prevent jams.
5. Load the stack face down in portrait orientation as illustrated on the next page.



Note: When printing envelopes, always be sure that the envelope flaps are facing away from the paper tray.



Caution: **Never** print on the backs of envelopes. Never overload the upper paper tray. The stack of envelopes should fit loosely into the channel formed by the paper guides.

6. Adjust the paper guides to the width of the stack.

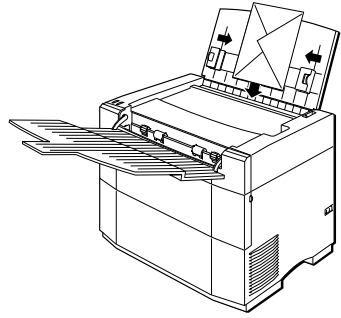

Envelopes must be inserted into the upper paper tray in the orientation as shown in the illustration at the right.

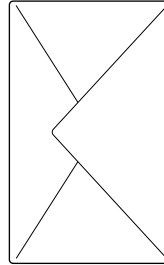

YES

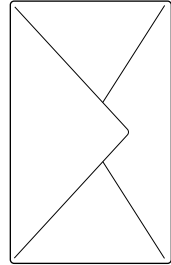

NO

7. Move the paper release lever to the back of the printer.

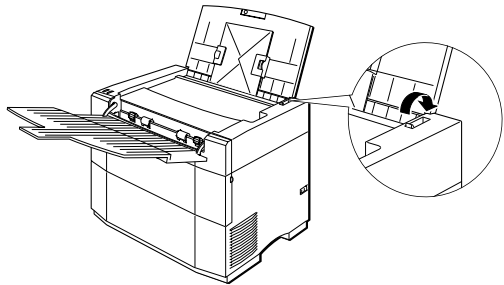

Note: Never add more media to a partially finished stack. Wait until the stack in the upper paper tray has been finished before loading another stack.

Caution: Only use envelopes recommended for laser printers to avoid paper jams or quality problems. Do not load more envelopes than the recommended amount because this will cause paper jams.

Chapter 3 Installing the printer driver and TrueType fonts

This printer comes with a printer driver and 35 TrueType fonts which are designed especially for Windows version 3.1 applications printing. It does not require any special add-in cards, cartridges or cables. It also differs from other printers in that it uses the computer's CPU to directly print your documents. When you upgrade to a more powerful computer, your printer performance is also improved. To operate the printer, however, you must follow these steps to install the printer driver software.

System requirements

To run this printer driver you need an IBM compatible PC with at least a 386SX 16-MHz CPU. Some older 386 computers cannot run in Windows *Enhanced Mode*, which means that this software will not work properly on those systems. You can verify this, if you have Windows installed on your computer, by typing WIN/3 at the MS-DOS prompt. If your computer cannot run Windows in *Enhanced Mode*, the system will tell you. This printer will not run on 286 based PCs and other earlier systems.

This printer requires at least 4 megabytes (MB) of PC memory (RAM) which is also the minimum amount of memory recommended by Microsoft Corporation for use with Windows version 3.1. By adding more memory to your computer, both your PC and printer's performance will increase.

This system software requires approximately 1.4 megabytes of disk space on your system's hard drive. An additional 1.85 megabytes is needed to install all of the 35 TrueType fonts. Up to approximately 8.5 megabytes of disk space is required for permanent virtual memory under Windows. If you have more than 4 megabytes of RAM, you won't need the entire 8.5 megabytes of virtual memory, which is described later in this Chapter. The total memory, PC RAM plus virtual memory, should add up to at least 12.5 megabytes, which is divided between your computer's RAM memory (which needs to be at least 4 MB) and Windows virtual memory. If your system has 4 MB of RAM, then you must allocate at least 8.5 MB of virtual memory in Windows. If you have 5 MB of RAM, then you need at least 7.5 MB of virtual memory, etc.

A math co-processor is not necessary, however, having one will increase the speed of PostScript emulation printing.

A Microsoft-compatible mouse is also highly recommended. This manual assumes that you are using a mouse. If you are not using a mouse, please refer to your Windows 3.1 Users Guide for information on using the keyboard in place of a mouse.

A standard PC parallel printer port is required to connect the printer using a high quality Centronics parallel cable.

Note: It is important that you use a properly manufactured cable. Using a poor quality cable may affect the output of this printer.

Printer command languages

This printer can receive data and interpret command languages through two standard command interpreters and also by directly using your computer's processing power. Those languages are 1) PostScript; 2) PCL and 3) Windows Direct.

It is strongly recommended that you use *permanent* virtual memory, rather than *temporary*. This can be changed through the **Control Panel** by following the steps below.

If you have not already designated the amount of virtual memory needed to run this printer with the current amount of RAM on your computer, or if you wish to convert to permanent virtual memory, do it now by using the **Control Panel**. These instructions assume that your system has a minimum of 4 MB of RAM and is running Windows 3.1 in Enhanced mode.

Steps:

1. Switch to the **Program Manager**.
2. Double-click on the **Main** group icon in the **Program Manager**.
3. Double-click on the **Control Panel** icon in the **Main** group.

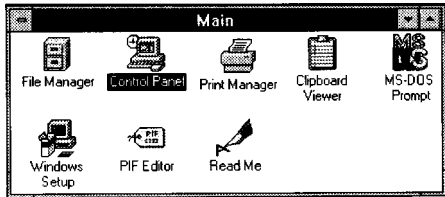

4. Double-click on the **386 Enhanced** icon.

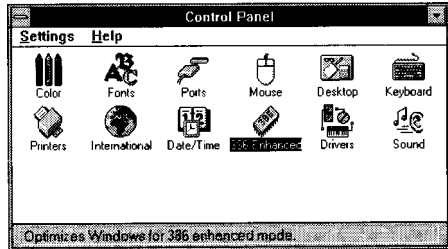

5. Click on the **Virtual Memory** button.
6. If the type is **Temporary** or **None**, click on the **Change** button.
7. Select **Permanent** from the **Type** menu under **New Settings**. (An X should appear in this box.)

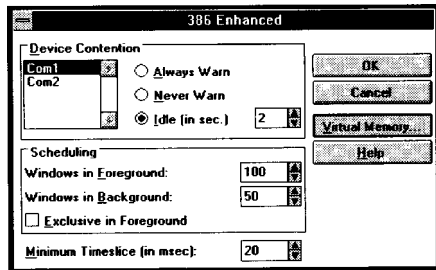

8. If required, increase the size of the virtual memory by typing in the amount of virtual memory you require in **New Size**, according to the following chart.

<u>PC RAM Size</u>	<u>Virtual Memory Requirements</u>
4 MB	8500K
5 MB	7500K
6 MB	6500K
7 MB	5500K
8 MB	4500K
9 MB	3500K
10 MB	2500K
11 MB	1500K
12 MB	500K
13 MB or more	None required

If the **New Size** shown in the **Virtual Memory** dialog box is less than the amount you need, you will need to correct the situation before proceeding by freeing up additional hard disk space on your computer.

9. Click **OK** to save your changes. You must click **Restart Windows** to implement these changes.
10. Click **Yes** to implement the changes, otherwise, click **No**.

Note: You cannot allocate more virtual memory than **Recommended Size** as displayed in the **New Settings** window.

If Windows won't let you allocate the required amount of disk space, check to make sure that you have enough room on your hard disk drive. If you have enough free disk space and Windows won't let you create large enough permanent virtual memory, you may need to run a disk defragmentation utility, such as MS-DOS 6.0's Defrag Utility, to clean up your hard disk drive before changing your virtual memory to *permanent*. In the meantime, you can use *temporary* virtual memory instead of *permanent*.

Note: If you are using a disk compression utility such as Microsoft's DoubleSpace or Stac Electronics' Stacker (versions below 4.0), permanent virtual memory must be located on the uncompressed drive (typically the D drive).

Note: If you need more information on Windows' virtual memory, refer to the Microsoft Windows 3.1 Users Guide.

Installing the printer driver and TrueType fonts

If at any time during installation of the printer driver you need help, press <F1> or choose <Help> on the **Setup** screen.

Note: Remember that you need at least 1.4 megabytes of hard disk space to install this printer driver and 1.85 megabytes of hard disk space to install the 35 TrueType fonts.
Always make a backup copy of each disk in the software package and store the original disks in a safe place. Use the backup copies to install the software.

Steps:

1. Insert disk #1 into the <A> drive. (Use the drive depending on your computer.)

2. In the Windows **Program Manager**, choose **Run** from the file menu.

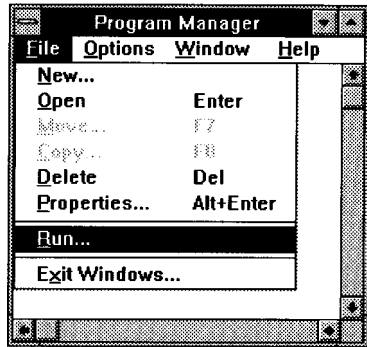

3. In the Command Line box, type "A:\WTSETUP" and press <Return>, if **A:** is the letter of the drive containing the software program. You can also select this by clicking on the Browse... and selecting the drive in which the software program floppy is located. Select WTSETUP.EXE and press OK.

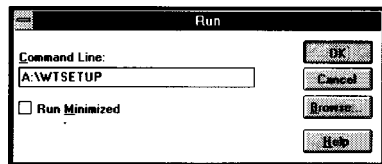

4. You will see the blue colored WinType **Setup** screen. Click the mouse anywhere on the screen or press any key to continue.

5. You will see the **Parallel Port Selection** screen. You must tell the **Setup** program which of the parallel ports you will be using. The choices are **LPT1**, **LPT2** or **LPT3**. The **Setup** program only shows those ports which are available on your system. The default port is **LPT1**.

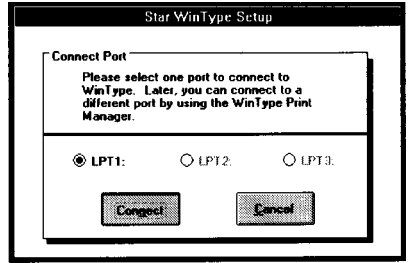

6. Click on **Connect** or press <**Return**> to continue.
This will display the **Directory Setup** screen.

Note: After installing the printer driver, you can select a different port by using the **WinType Print Manager**.

Note: If you select another drive on which to install the printer driver, it must have at least 1.4 MB of free hard disk space for the system files and 1.85 MB for all 35 TrueType fonts.

7. The **Setup** program will create and set up the directory, "**C:\WINTYPE**", as the default installation directory. You can change the default directory and/or drive now by specifying a new name. Click **OK** if you are satisfied with the name or click **Cancel** to ignore the change.

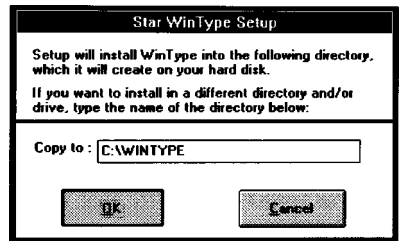

Note: If you changed the directory name, it is helpful to write the new directory name somewhere in this manual. You should keep it handy, in case you should ever want to remove this printer driver software.

8. As the **Setup** program copies the software program to the specified directory, it will prompt you to insert the additional disk as needed.

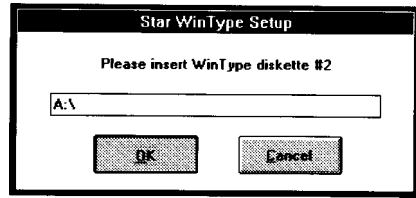

Note: As the installation is being carried out, the install program will display messages and will show you the progress of the installation.

Note: The **Setup** program will modify the Windows initialization files so that the printer driver will run properly when you start Windows.

9. When the program installation is complete, you will see a message that tells you that the **WinType Setup** program will install the 35 TrueType fonts. If you click **OK**, the install program will prompt you to insert disk #3. Clicking **Cancel** will ignore the font installation and prompt you to restart Windows.

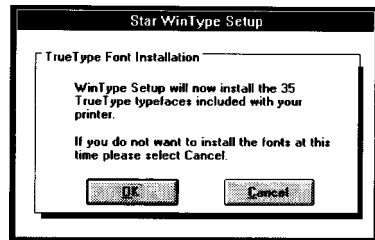

The **Setup** program also creates the **WinType Tools** group. This group contains icons for the WinType programs, including the **Star WinType Print Manager**, the **Star WinType TEST**, the **Star WinType Help** and the **Star WinType Un-install** program. When the printer is active, you will be able to run these programs by double-clicking on their icons.

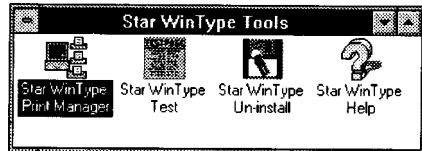

10. When the TrueType fonts have been installed, the **Setup** program will display a message telling you that setup was successful and to restart in order to activate the WinType printer. Choose "**Restart Windows**" to restart or choose **Exit** to quit the **Setup** program.

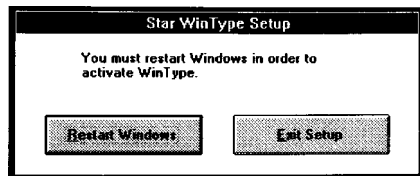

Note: You must restart Windows before you can operate this printer.

11. When Windows is restarted, the **Star WinType TEST** Utility will check to make sure that all of the print modes work correctly. The test utility will print several pages during the test, including a configuration page containing information about your system and printer.

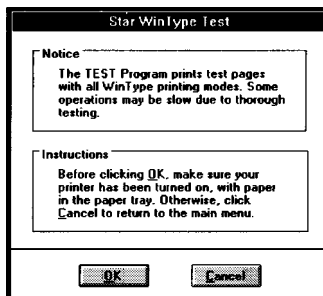

Star WinType 4000 Configuration

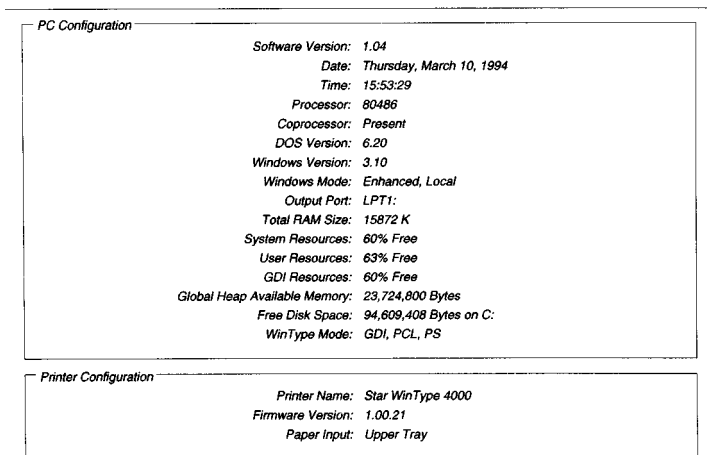

Caution: Make sure that the printer is turned on and that there is enough paper in the paper tray to perform this test.

Note: It is a good idea to save a copy of the most recent configuration page with this manual because it may be useful if you ever have to call Customer Service.

12. If the installation is completed successfully, **WinType** device names will appear in the **Printers** window of your **Control Panel**.

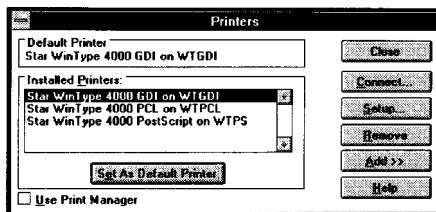

Removing the printer driver software

If you should ever need to remove the printer driver software from your system, use the Un-install icon in the **WinType Tools** Group.

Steps:

1. From **Program Manager**, double-click on the Star **WinType Tools** Group.
2. Double-click on the Star **WinType Un-install** icon.



3. Click on **Yes** to remove all Star **WinType** printer drivers and restore your Windows initialization files. Otherwise click on **No**.

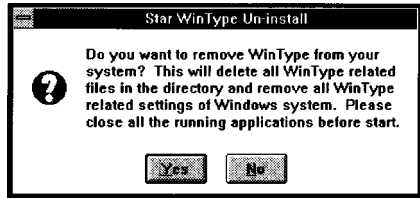

4. Exit Windows
5. Restart Windows

Chapter 4 Printing with WinType 4000

The WinType 4000 printer driver has three print modes from which you can choose. They are the Windows Direct (GDI), PostScript and PCL modes. These three printing modes can be easily selected to meet your specific printing requirements. This chapter explains these different print modes and how you can select and use them.

Windows Direct (GDI) mode

The Windows Direct (GDI) mode uses the processing power of your computer to print in the Windows operating environment. It provides fast WYSIWYG (What You See Is What You Get) printing output which is twice as fast as standard printers under most Windows applications.

Windows Direct (GDI) mode takes advantage of Windows own internal design to produce documents faster than most conventional printers. Other printers require Windows to translate a document into a special printer language, such as PCL on LaserJet printers. Windows Direct (GDI) mode reduces printing time by eliminating this translation step before starting to print. This mode also includes some additional useful features, such as duplex printing.

Windows Direct (GDI) mode works well for most software packages. However, certain applications and certain graphics files will look more polished when printed using a more sophisticated printer language, like PostScript. Also, Windows Direct (GDI) mode uses Windows functionality which is not available when running non-Windows applications. For these reasons, the WinType 4000 includes PostScript and PCL emulation modes. We'll explain how to select these modes later.

PostScript mode

PostScript mode printing gives you the ability to print high quality and sophisticated documents in Windows and DOS applications within the Windows environment.

PostScript mode is good for printing files with sophisticated embedded graphic images. Because Windows may not always display graphic intensive files accurately, try printing those files with the PostScript mode. The WinType software supports additional PostScript-compatible Type1 software fonts such as Adobe's Type Manager (ATM).

PCL mode

The printer duplicates the functionality of Hewlett-Packard LaserJet IIP with some minor exceptions. PCL *emulation* gives you the ability to print from a DOS application running within Windows and from the MS-DOS command line within Windows.

Features of the printer driver software

This printer driver software includes the following capabilities.

- Printing from any Windows 3.1 application.
- Printing DOS applications through Windows
- Printing from DOS command line within Windows
- Print manager (print spooler)
- On-line help files
- Printer and printing status information

Printing with the Windows Direct (GDI) mode

GDI mode works best for very fast printing in Windows applications. Use the following steps to select the Windows Direct mode.

Steps:

1. Switch to the **Program Manager**.
2. Open the **Main** group by double-clicking on its icon.
3. Double-click on the **Control Panel** icon in the **Main** window.
4. Double-click on the **Printers** icon in the **Control Panel** window.

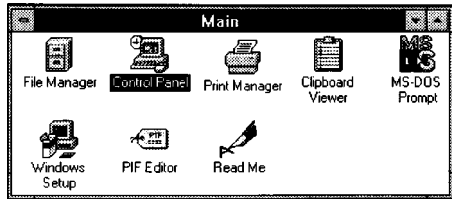

5. Double-click on the **Printers** icon in the **Control Panel** window.

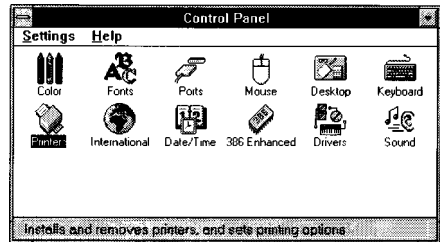

6. Double-click on the **Star WinType 4000 GDI on WTGDI**. This will select the GDI mode as your default printer.

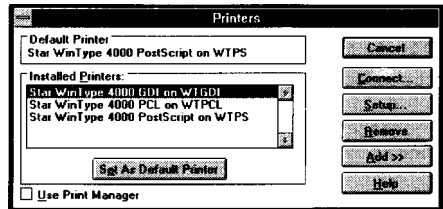

Note: Most popular Windows applications also have shortcuts to the printer setup screen which allows you to make changes without having to go through the Control Panel.

6. Click on the **Setup** button.
You will see a window which looks like the one on the right.

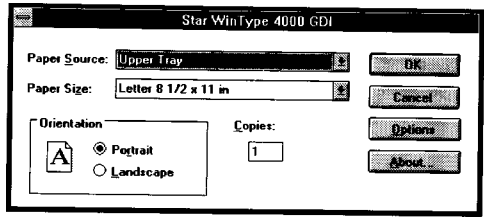

In the **Setup** dialog box, you can set the **Paper Size**, the number of **Copies** (from 1 to 99) and the **Orientation** of the paper. A complete listing of the types of paper and other media types is in Chapter 2.

- Note:** The **Setup** screen in GDI mode lets you select the following items:
- Paper size
 - Number of printed sets (1 — 99)
 - Portrait or landscape style printing

Caution: Remember that this printer can hold up to 100 sheets in the paper tray. Overloading the paper tray will cause the paper to jam. You must never select any port other than WTGDI in the Connect box of the Printers menu. If you want to change the port from LPT1 to LPT2 or LPT 3, use the **Star WinType Print Manager** to make these changes.

7. Clicking on the **Options** button will call up the **Options** dialog box, shown at right, which is where you can make the following selections.

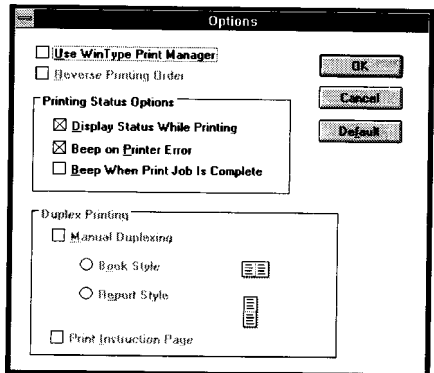

- Clicking on the **Use WinType Print Manager** will cause the printer driver to always display the **WinType Print Manager**. The **WinType Print Manager** is explained in Chapter 5.
- If you have **Use WinType Print Manager** selected, you can also click on **Reverse Printing Order** which will print your document from the highest page number to the lowest page number.
- If you have **Use WinType Print Manager** selected, you can also select **Manual Duplexing**.

- Note:** This printer will print faster if the **WinType Print Manager** is turned OFF.
- Note:** **Printing Status Options** are only available when the **Use WinType Print Manager** is not selected in this dialog box. However, you can enable and set up the **Printing Status Options** from within the **WinType Print Manager**. See Chapter 5 for details.

- Clicking the **Display Status While Printing** box, described in Chapter 6 **Print Status Window**, will cause the **Print Status Window** to appear whenever you print, as shown in the illustration at the right. The print status window includes an animated illustration of this printer to show you the progress of your printing job or to inform you of any errors.

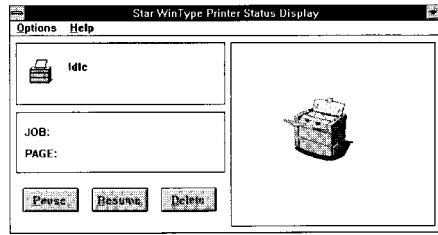

- Clicking the **Beep on Printer Error** box will cause the system to beep when an error occurs.
- Clicking the **Beep when Print Job is Complete** box, will cause the system to beep to inform you that a print job is finished.
- Clicking **Manual Duplexing** under **Duplex Printing** will allow you to print either the **Book Style** or the **Report Style**. Both styles are explained on the next page.
- Clicking **Print Instruction Page** will cause the printer to output the instructions for the Duplexing style you have selected. These easy to understand instructions are printed before the first page of your print job to help you follow the job through easily.

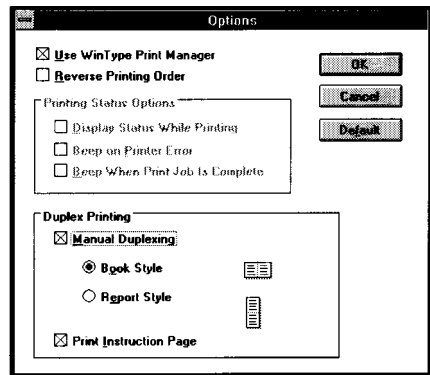

8. Click the **OK** button if you are satisfied with the changes you have made. You will return to the **Setup** window. Click the **Cancel** button to exit the window and ignore any settings you have made.
9. Click **OK** to exit the **Setup** window and to save your changes.
10. Click on **Close** to exit the **Printers** menu and to save your printer selection.
11. Click on **Settings** and select **Exit** to exit the **Control Panel** window

Manual duplex printing

Manual duplex printing, which is a feature of the Windows Direct (GDI) mode, allows you to print on both sides of the page. Two duplexing styles are available - **Book Style** and **Report Style**. **Book Style** printing prints your document so that if you opened it in the same way as you opened this manual, for example, the even and odd numbered pages would face each other on the left and right, respectively. In **Report Style**, the printer will output the even numbered pages upside down so that if you opened the document in the same way as a report that has been bound at the top, the even and odd numbered pages would face the same way and will border on the top and bottom of the pages. You can perform manual duplex printing by clicking on the style you want and following the steps explained below.

Note: Manual duplex printing is available only when the **Star WinType Print Manager** is clicked ON.

Steps:

1. Open the **Options** screen in the **WinType 4000 GDI** printer setup by following steps 1-6 on pages 26-27.
2. Click on **Use WinType Print Manager**.
3. Click on **Manual Duplex Printing**.
4. Click on the duplexing style you prefer
- **Book Style** - bound on the side or
- **Report Style** - bound at the top.
5. If the **Print Instruction Page** is not checked, click this box.
6. After selecting the style that you want to print, start your print job in the usual manner. The printer will print every odd-numbered page of your document, starting from page 1.

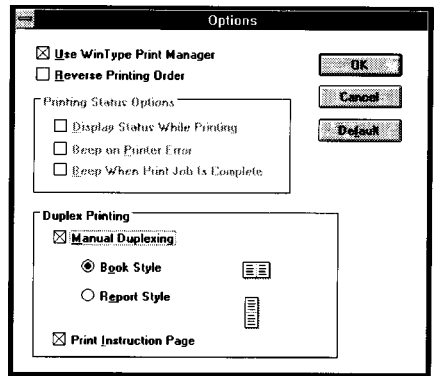

Caution: If you are going to print multiple copies of your manually duplexed documents, **ALWAYS** input the number of copies you want to print in the **Copies box** in the **printer driver dialog box**. Do **not** input the number of copies into the **Copies box** of the **Print Command dialog box**.

7. Pick up your printed papers, straighten them and reinsert them face up into the upper paper tray.

Note: Some printed sheets may become curled. Curled sheets may cause paper jams. **Always** straighten the sheets **before** reinserting them into the upper paper tray.

Duplex printing errors

If an error occurs during **Duplex Printing**, please use the following procedures to recover.

- If an error (e.g. paper jam) occurs while you are printing the front side of the page - the odd numbered pages - clear the error as instructed in the **Print Status Window**. Click the **Resume** button to continue the current duplex printing job as usual.
- If an error occurs while printing the back side of the page - the even numbered pages - clear the error as instructed in the **Print Status Window**. If the page being printed when the error occurs is damaged, insert a new piece of paper into the printer after removing the damaged one. Click the **Resume** button to continue printing. After all pages are finished printing, reinsert that new piece of paper and reprint the corresponding odd numbered page on the opposite side.

Using fonts in the Windows Direct (GDI) mode

The usefulness of the WinType 4000's "What You See Is What You Get" method is apparent when you use fonts. In Windows, any font you can see on the screen will work with this printer. This includes TrueType, 35 of which have been bundled with this printer driver, Adobe Type Manager (Type 1) and Intellifont for Windows font formats.

TrueType fonts are usually the most efficient, since they are already built into Windows 3.1. In most cases, there is negligible performance difference between TrueType and other kinds of fonts such as Type 1 and Intellifont.

One advantage of the Windows Direct (GDI) mode becomes clear as you work with documents using many different types of fonts. A standard printer language, such as PostScript, must get the font information each time it processes a new font in a document. Therefore, a document using a large number of different fonts can take a noticeably long time to print. In Windows Direct (GDI) mode, font information is processed at the time that the document is retrieved and displayed on your screen. For that reason, Windows printing requires only a small amount of time for processing. In the end you are able to get fast text printing regardless of the number of fonts you employed.

Note: Windows includes some special built-in fonts that were not meant for printing, including **Helv** and **Tms RMn**. These fonts were designed for screen display so their resolution is coarser than the fonts normally used for printing. We recommend that you should not select these fonts when you create your document. If you only need TrueType fonts, which are usually identified with a TT symbol on your font list, you can eliminate them from appearing in your application using the procedure below. These screen fonts will remain on your hard disk for needs that may arise in the future.

Eliminating screen fonts from your application

Steps:

1. Switch to the **Program Manager**.
2. Open the **Main** group in the **Program Manager** by double-clicking on its icon.
3. Double-click on the **Control Panel** icon.
4. Double-click on the **Fonts** icon.

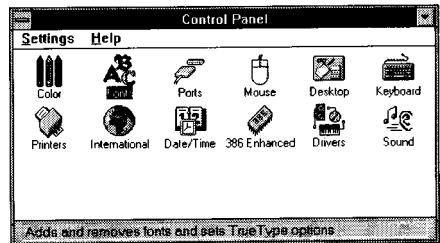

5. Click the **TrueType** button.

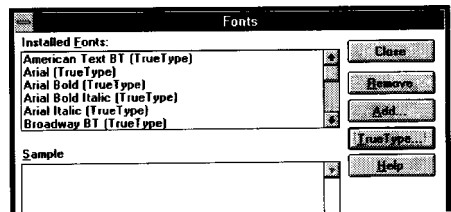

6. Select **Show Only TrueType Fonts in Application**, and click **OK** to exit this window.

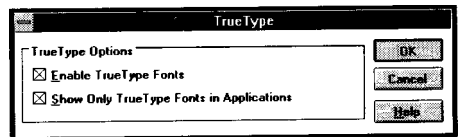

7. Click **Close** to exit the **Fonts** window.
8. Select **Exit** from the **Settings** menu to exit the **Control Panel** window.

Note: The WinType printer driver installation routing automatically tells Windows to display only TrueType fonts. If you would like to display other font formats as well, use the above procedure but remove the X from the **Show Only TrueType Fonts in Applications** by clicking on the box.

Printing with the PostScript mode

PostScript mode is used to print graphics intensive files made using Windows applications or DOS applications through Windows. PostScript printing uses the power of your PC to "draw" an exact replication of your document in a PostScript format before sending it to be printed. Although printing with the PostScript mode is slower than the other modes, the output is of the highest quality. Use the following steps to setup your printer to print with the PostScript mode.

Printing from a Windows application

Note: While the WinType 4000 can print Windows applications in PostScript or PCL modes, we recommend printing Windows applications via Windows Direct GDI mode. This mode ensures the best and most efficient printing.

Steps:

1. Switch to the **Program Manager**.
You will see a group titled **Main**.
2. Double-click on the **Main** group icon to open this window.
3. Double-click on the **Control Panel** icon in the Main window.
4. Double-click on the **Printers** icon in the **Control Panel** window.

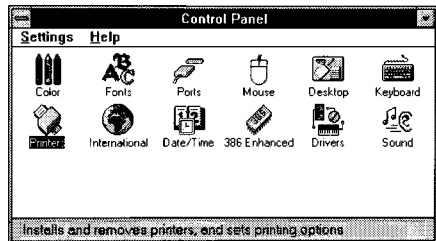

5. Double-click on the **Star WinType 4000 PostScript on WTPS**.

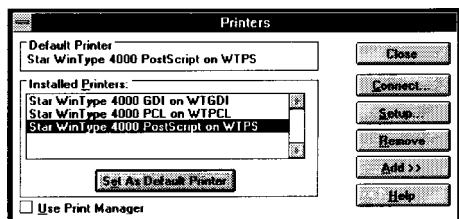

6. Click on the **Setup** button.
You will see a window which looks like the one on the right.
In the **Setup** window, you can change the **Paper Size**, **Orientation** and make any further adjustments you need through the **Options** button. For additional information on these features and advanced options click on the **Help** button.
7. Click **OK** to exit the **Setup** window and to save your changes.
8. Click on **Close** to exit the **Printers Menu** and to save your printer selection.
9. Click on **Settings** and select **Exit** to exit the Control Panel window.

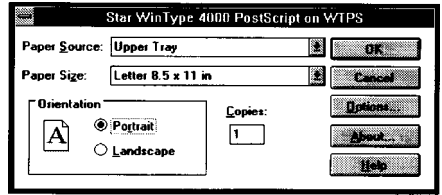

Note: If you have a file saved in PostScript language format (.EPS files) you can print from the MS-DOS command line from within Windows. At the command line prompt, type:
COPY/B <filename.ext> TO LPT1
 where <filename.ext> is the name of your PostScript-formatted file.
 If you have your printer configured to print to a different parallel port, give its name instead of LPT1.

Fonts in PostScript Mode

The PostScript mode supports all TrueType fonts, Type 1 fonts (ATM) and Intellifonts for Windows. The WinType 4000's PostScript mode also emulates the original 13 resident PostScript printer fonts by substituting these fonts as TrueType fonts. The substitutions are as follows.

Original PostScript Font Name

Helvetica
 Helvetica Bold
 Helvetica Oblique
 Helvetica BoldOblique

Courier
 Courier Bold
 Courier Oblique
 Courier BoldOblique

Times Roman
 Times Roman Bold
 Times Roman Oblique
 Times Roman BoldOblique
 Symbol

TrueType Substitute

Arial
 Arial Bold
 Arial Italic
 Arial BoldItalic
 CourierNew
 CourierNew Bold
 CourierNew Italic
 CourierNew BoldItalic

TimesNewRoman
 TimesNewRoman Bold
 TimesNewRoman Italic
 TimesNewRomanBoldItalic
 Symbol

In order to expand font support to emulate the full 35 original PostScript printer fonts, you will need to purchase Microsoft's Font Pack 1. Font Pack 1 is sold and supported by Microsoft Corporation.

If you decide to purchase Font Pack 1, the WinType 4000's PostScript mode will emulate these 35 PostScript printer fonts by substituting these fonts as TrueType fonts. See the list below.

Original PostScript Font Name

Courier
Courier Bold
Courier Oblique
Courier BoldOblique
Times Roman
Times Roman Bold
Times Roman Oblique
Times Roman BoldOblique
Helvetica
Helvetica Bold
Helvetica Oblique
Helvetica BoldOblique
Symbol
Palatino Roman
Palatino Bold
Palatino BoldItalic
Palatino Italic
Helvetica Narrow
Helvetica Narrow Bold
Helvetica Narrow Oblique
Helvetica Narrow BoldOblique
Bookman Light
Bookman Demi
Bookman DemiItalic
Bookman LightItalic
AvanteGarde Book
AvanteGarde Demi
AvanteGarde DemiOblique
AvanteGarde BookOblique
NewCenturySchlbk Roman
NewCenturySchlbk Bold
NewCenturySchlbk BoldItalic
NewCenturySchlbk Italic
ZapfChancery MediumItalic
ZapfDingbats

TrueType Substitute

CourierNew
CourierNew Bold
CourierNew Italic
Courier BoldItalic
TimesNewRoman
TimesNewRoman Bold
TimesNewRoman Italic
TimesNewRoman BoldItalic
Arial
Arial Bold
Arial Italic
Arial BoldItalic
Symbol
BookAntiqua
BookAntiqua Bold
BookAntiqua BoldItalic
BookAntiqua Italic
ArialNarrow
ArialNarrow Bold
ArialNarrow Italic
ArialNarrow BoldItalic
BookmanOldStyle
BookmanOldStyle Bold
BookmanOldStyle BoldItalic
BookmanOldStyle Italic
CenturyGothic
CenturyGothic Bold
CenturyGothic BoldItalic
CenturyGothic Italic
CenturySchoolbook
CenturySchoolbook Bold
CenturySchoolbook BoldItalic
CenturySchoolbook Italic
MonotypeCorsiva
MonotypeSorts

Printing DOS applications in PostScript mode under Windows

To print your DOS applications while running under Windows, please follow the steps explained below.

Steps:

1. Select and setup the **Star WinType PostScript** driver by following steps 1-9 explained on pages 32 - 33.
2. Launch your DOS application by using one of the following methods.

• DOS Prompt Method

1. Double-click on the **MS-DOS** prompt icon from the **Main** Group in the Windows **Program Manager**.
2. Begin the DOS application as normal according to your application's user manual.
3. Follow the instructions for setting up your default printer.
4. Select either PostScript® printer or Apple LaserWriter Plus in your DOS application. Refer to your DOS application's Users Manual for details on selecting a printer.
5. Select the command to print.

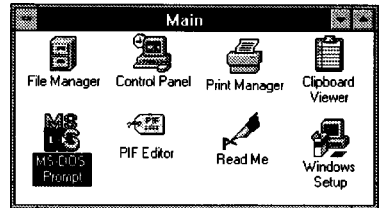

• .PIF File Method

1. Double-click on your .PIF DOS application icon. This icon was either created by you or supplied to you by your application program.
2. Follow steps 2-5 from the DOS prompt method described above.

Note: When you are finished with your DOS application, you must type **Exit** at the command line prompt (eg. C:>) to return to Windows.

Printing with the PCL mode

As mentioned before, the PCL emulation gives you the ability to print from a DOS application running under Windows, and from the MS-DOS command line from within Windows. While this is similar to the PostScript mode, it is, however, slightly more complex. You can select PCL from many Windows applications use the following steps in the **Control Panel** in Windows to select the PCL mode.

Printing in PCL mode from a Windows application

Note: While the WinType 4000 can print Windows applications in PCL mode, we recommend printing Windows applications via Windows Direct (GDI) mode. This mode ensures the best and most efficient printing.

Steps:

1. Switch to the **Program Manager**.
You will see a group titled **Main**.
2. Double-click on the **Main** group icon to open this window.
3. Double-click on the **Control Panel** icon in the Main window.
4. Double-click on the **Printers** icon in the **Control Panel** window.

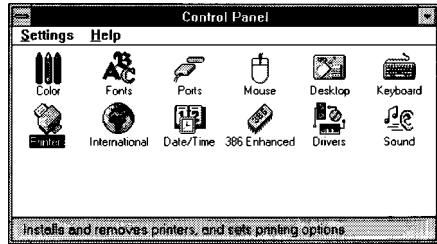

5. Double-click on the **Star WinType 4000 PCL on WTPCL**. This will select the PCL mode as your default printer.

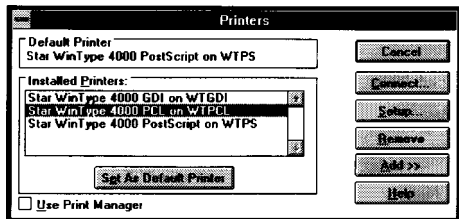

6. Click on the **Setup** button. You will see a window which looks like the one on the right. In the **Setup** window, you can change the **resolution, paper size, memory, orientation, number of copies** and make any further adjustments you need through the **Options** button. For additional information on these features and advanced options, click on the **Help** button.
7. Click **OK** to exit the **Setup** window and to save your changes.
8. Click on **Close** to exit the **Printers** menu and to save your printer selection.
9. Click on **Settings** and select **Exit** to exit the Control Panel window.
10. Once you have selected this mode, and made any setting changes. You can print from your Windows application just as you would to any other printer.

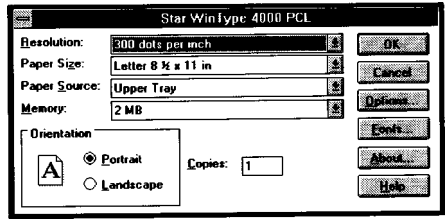

Printing DOS applications in PCL mode under Windows Steps:

1. If your default printer is already setup for either **WinType 4000 GDI on WTGDI** or **WinType 4000 PCL on WTPCL**, move to **Step 3**.
2. Follow steps 1-10 on pages 36 - 37 (PCL mode setup) or steps 1-10 on pages 26 - 28 (Windows Direct (GDI) mode).
3. Launch your DOS application by using one of the following methods.
 - DOS Prompt Method
 1. Double-click on the **MS-DOS** Prompt icon from the **Main** group in the Windows **Program Manager**.
 2. Begin the DOS application as normal according to your application's user manual.

3. Follow the instructions for setting up your default printer.
4. Select the **HP LaserJet IIP** driver in your DOS application. Refer to your DOS application's Users Manual for details on selecting a printer.
5. Select the command to print.

- **.PIF File Method**

1. Double-click on your **.PIF DOS** application icon. This icon was either created by you or supplied to you by your application program.
2. Follow steps 2 - 5 from the DOS prompt method described above.

Note: When you are finished with your DOS application, you must type Exit at the command line prompt (eg. C>) to return to Windows.

Note: The WinType 4000 is a Windows printer. The Window's Direct (GDI) mode is based on Windows 3.1 and will not work with MS-DOS. However, the WinType 4000 will work in PCL mode if you launch an MS-DOS application from within Windows. The WinType 4000 will not run properly if you exit Windows completely.

Fonts in PCL Mode

PCL mode supports several resident fonts which correspond to the internal fonts of the HP LaserJet IIP. They are:

- Courier: 10 point; 12 pitch; Regular, Bold and Italic.
- Courier: 12 point; 10 pitch; Regular, Bold and Italic.
- Line Printer, 8.5 pint, 16.66 pitch Regular

You can select these resident fonts in this printer driver in PCL mode. The steps are outlined below.

Steps:

1. Switch to the **Program Manager**. You will see a group titled **Main**.
2. Double-click on the **Main** group icon to open this window.
3. Double-click on the **Control Panel**.
4. Double-click on the **Fonts** icon.
5. Click on the **TrueType** button.
6. Disable the **Show Only TrueType Fonts in Applications** by clicking the check-box. The X should not appear in this box.
7. Click **OK** to close the **TrueType** window.
8. Click on the Control-Menu box in the upper left hand corner of the **Fonts** window. Select **Close** to close the **Fonts** window.
9. Click on **Settings** and select **Exit** to exit the **Control Panel** window.
10. Select the resident fonts through your application as you would with any other kind of font.

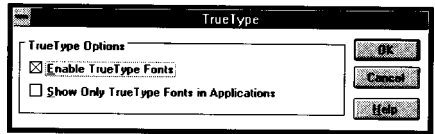

Note: When a font has not been selected, Courier 12 point regular is the default setting.

Recovering from an error message in PCL or PostScript modes when running a DOS application from within Windows

If you are running a DOS application when a printer error or status message occurs, (eg., Warming up, Paper Out, Paper Jam, etc.) the **Star WinType Printer Status Display** will automatically appear on your screen. Since this advanced messaging feature is a Windows utility, your DOS application will be temporarily suspended and your computer screen will display your Windows 3.1 desktop.

Once you correct the printer problem by following the screen messages, the **WinType 4000** will complete the print job but you will remain in the Windows desktop display. You can easily return to your DOS application by following one of the methods explained below.

Keyboard Method

Steps:

1. While holding down the **ALT** key on your computer keyboard, press the **TAB** key until you see the illustration at the right.
2. Release both the **ALT** and **TAB** keys to return to your DOS application.

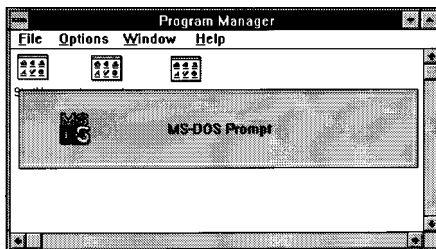

Mouse Method

Steps:

1. At the bottom of your screen, there will be an MS-DOS prompt icon which looks like the illustration at the right.
2. Double-click on the MS-DOS prompt icon to return to your DOS application.



Note: The minimized MS-DOS Prompt icon may not be visible on your screen if you are displaying any open windows as full screens. To make this icon visible, you must reduce the size of all open full screen windows (eg. Program Manager). Please refer to your Microsoft Windows 3.1 Users Guide for an explanation on changing the size of a window.

Saving download fonts and macros in the PCL mode

By default, when your application prints using the PCL mode, the PCL emulation interpreter will start up, print your document and then automatically shut itself off. This means that the PCL interpreter will not take up memory on your computer except when needed.

However, when the PCL interpreter turns itself off, all of the fonts and macros that you have downloaded will be lost. This is the same for a conventional printer when turned off. You can save these fonts by using the Print Manager to keep the PCL interpreter active. Just use the following steps.

Steps:

1. Select the **Star WinType PCL** printer as described on page 36.
2. Double-click on the **Print Manager** icon in the **WinType Tools** group in the **Program Manager** window.
3. You can Minimize the **Star WinType Print Manager** to an icon if you like by clicking on the button in the upper right hand corner of the title bar.
4. Download macros or soft fonts in advance, using the download utility provided by your application's font program.
5. Start or return to your application and print your document.



Saving your fonts and macros will help decrease processing time because the PCL emulation interpreter has already been loaded. However, if you switch from PCL to another mode, downloaded information will be lost, just as is if you were changing languages in a conventional printer.

Chapter 5 The Star WinType Print Manager

The Star WinType Print Manager helps you manage the output flow and the operation of your printer. You can see all the files waiting to be printed and you can change their order. You can also see how much of the current print job has already been processed. You can control the priority setting for printing relative to other applications running at the same time. Also, with the WinType Print Manager, you can print double-sided (manually duplexed) pages in the Windows Direct (GDI) mode. When minimized, the print manager appears as an icon at the bottom of your screen. In this chapter, we'll explain the various facets of this program.

Enabling the WinType Print Manager

If you plan to print in the Windows Direct (GDI) mode (Star WinType 4000 GDI on WTGDI) and use the **Star WinType Print Manager**, you must first enable this Print Manager. Use the following steps to enable the **WinType Print Manager**.

Steps:

1. Switch to the **Program Manager**.
2. Open the **Main** group by double-clicking on its icon.
3. Double-click on the **Control Panel** icon in the **Main** window.
4. Double-click on the **Printers** icon in the **Control Panel** window.

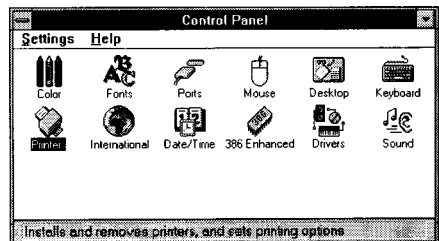

5. Double-click on the **Star WinType 4000 GDI on WTGDI**. This will select the GDI mode as your default printer.

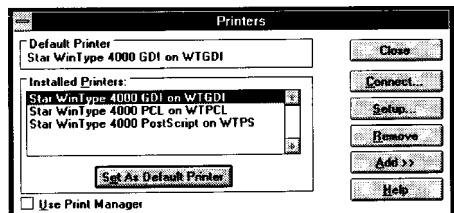

6. Click on the **Setup** button.
7. Click on the **Options** button.

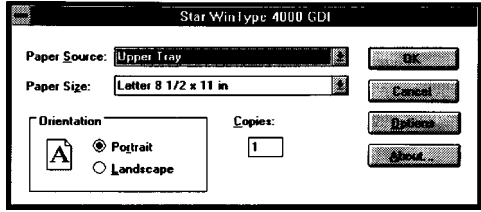

8. If the **Use WinType Print Manager** has not been selected, click on the check-box to put an X in it.

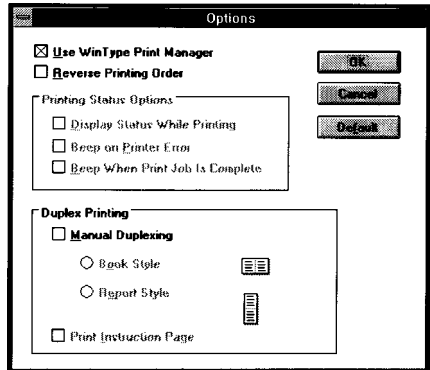

9. Click **OK** to exit the Options window and to save your changes.
10. Click **OK** to exit the Setup window and to save your changes.
11. Click on **Close** to exit the Printers window and to save your printer selection.
12. Click on **Settings** and select **Exit** to exit the **Control Panel** window.

Viewing and accessing the WinType Print Manager

There are two methods to access the **Star WinType Print Manager**. You can use either method.

Method One

1. Open the **Star WinType Tools** Group in the **Program Manager** by double-clicking on the icon.
2. Double-click on the **Star WinType Print Manager** icon



Method Two

1. If the **Star WinType Print Manager** is already opened but minimized (eg. after starting a print job), double-click on the minimized icon.
2. After printing is completed, you can close the **Star WinType Print Manager** by clicking on the Control-Menu box on the upper left hand corner of the title bar.



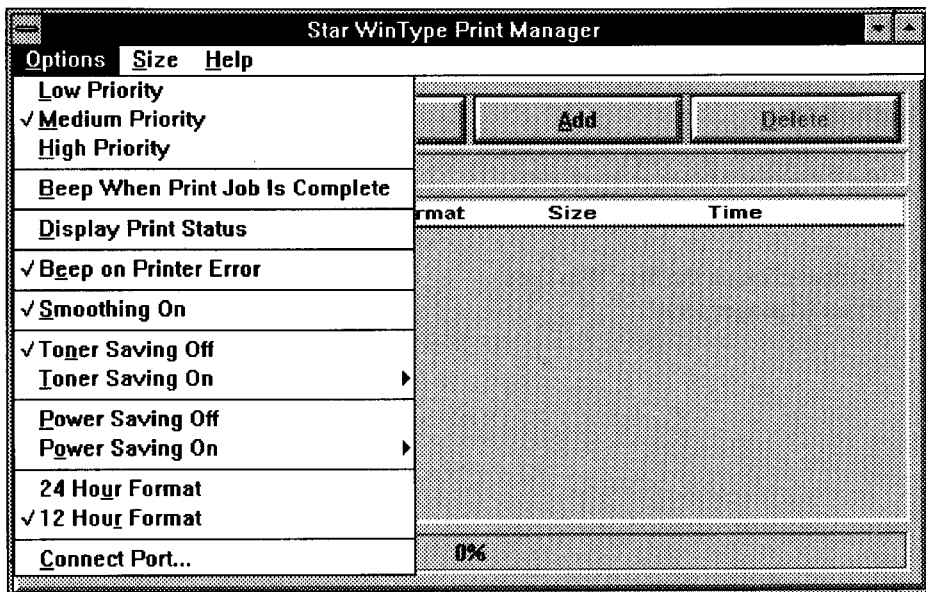

Options:

1. Priority

Windows lets you run several applications at the same time. This helps productivity, but it also means that you are sharing your computer's power among several different activities.

These priority settings let you control the priority order of the printing jobs relative to other applications which may be running at the same time.

The **Options** menu lets you choose between **High**, **Medium** and **Low** priority processing when you print. When you select **High** priority, the output is faster but it will slow down your system. Conversely, when you select **Low**, your other applications will run faster, but your document will take longer to print. A check mark () indicates the current setting. You can change the priority by clicking on the desired selection. Medium priority is the default setting.

2. Beeps

If you check **Beep When Print Job is Complete**, your system will beep when the printing job is done. If you check **Beep on Printer Error**, your system will beep when a problem occurs with the printer. A check mark () indicates that the feature is turned on. The default setting for the beep features are as follows.

Beep When Job is Complete (Off)

Beep on Printer Error (On)

3. Display Print Status

This item, when clicked, will pop up the **Print Status Window** when you print. If this is not selected, the **Print Status Window** will only be displayed when an error occurs. A check mark () indicates that this feature is on. The default setting is off.

4. Smoothing On

This option smooths text and graphic edges to give you 600 dpi class resolution. A check mark () indicates that the smoothing feature is on. Click on it to change the setting. Smoothing On is also referred to as Edge Enhancement Technology (EET). The default setting is on.

5. Toner Saving Mode

This printer has a built-in feature that extends toner life. This feature is called **Toner Saving Mode**. For print jobs that require the best resolution, choose **Toner Save Off**. This is the default setting. For draft documents, choose **Toner Save On** and select the setting that best suits your needs.

If you choose **Toner Save On**, you must also click on one of the settings (**Dark**, **Medium** or **Light**). Dark uses more toner, but produces higher quality print. Light uses the least amount of toner, but produces lower quality print. Using less toner to print your documents will allow you to print more documents per toner cartridge.

6. Power Saving Mode

This printer has a built-in power saving mode. After idling for 15 minutes (default), the printer will reduce its power consumption by shifting into a power saving mode. You can select either "**Power Saving Mode On**" or "**Power Saving Mode Off**." If you choose the latter, your printer will remain active and will consume more power.

When you select "**Power Saving Mode On**," you can select an interval from 1 to 15 minutes. After the specified time of idling, the printer will automatically enter the power saving mode and the left panel power lamp will blink slowly. The printer will "wake-up" as soon as you send a print job to the printer.

7. Time Format

You can choose the way time is displayed with this option. There are two selections: 12 hour or 24 hour formats. 12 hour format displays time like 2:15 P.M. as: 02:15 PM and 24 hour would display that time as 14:15. A check mark () indicates which format is being used. The default setting is the 12 hour format.

8. Connect Port

This port option lets you select a different parallel port for your printer. Your computer may not have all of these ports, but **LPT1**, **LPT2**, **LPT3** are the selections available. The steps for operation are below.

Steps:

1. Click on **Connect Port**.
2. Click on either **LPT1**, **LPT2** or **LPT3**.
If **LPT2** or **LPT3** do not exist on your PC, these ports choices will be displayed in gray and you will not be able to select them.
3. To save your setting, click on **Restart Windows**. Otherwise, click **Cancel**.

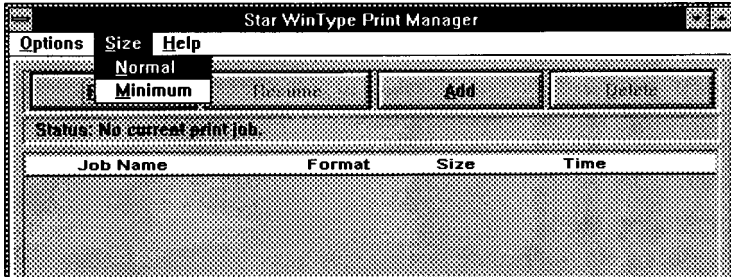

Size

This menu lets you change the size of the display window for the **Star WinType Print Manager**.

1. **Normal** will display information on your screen including Job Name, Printer language format, Print Job Size (in bytes) and the time of day the job was created.
2. **Minimum** will take up less space on your screen, but limits the information to Job Name and Format.

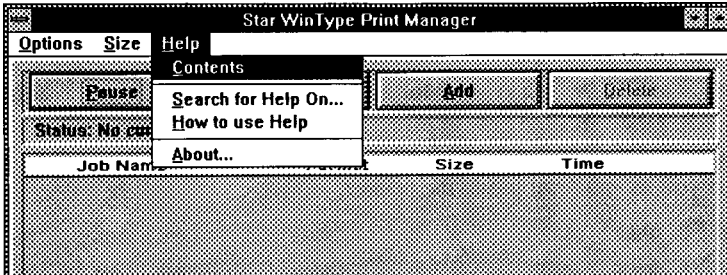

Help

1. **Contents**

This gives you a list of subjects available in the help menu.

2. **Search for Help On...**

This will open up a window allowing you to get helpful information on other printer features.

3. **How to Use Help**

This is a standard Windows Help guide to instruct users how to access the help menu.

4. **About**

The **About** option provides you with the information about the version of printer driver software version you are currently using.

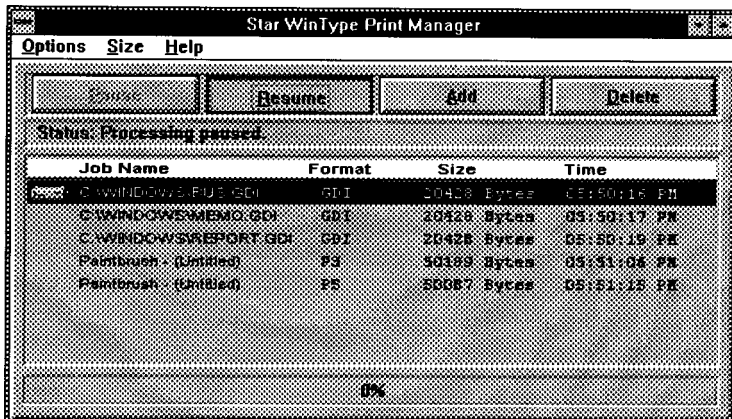

Queue information

This part of the **Star WinType Print Manager** screen shows the print jobs in the queue waiting to be printed. The following describes each element of this program.

Job Name

This shows the name of the application used to create the document and the file name.

Format

This will show one of the three print modes: Windows Direct (GDI), PostScript or PCL (Printer Command Language)

Size

This shows the print job size in bytes.

Time

This is the time of the day the print job was created.

Display of information

On a color monitor, the current job being printed will be displayed in dark blue. A job that you have selected with your mouse will appear against a light blue background.

On a monochrome monitor, the current job will be highlighted. A paused or a selected job will also appear highlighted, but somewhat darker gray than the current job.

Changing priority in the queue

The **Star WinType Print Manager** will send the first job in the queue to the printer first. If you have a mouse, you can change the order of print jobs that remain in line by following a "drag-and-drop" procedure.

Steps:

1. Open the **Star WinType Print Manager** by following the **Steps** on pages 43 - 44.
2. Move the mouse to the entry that you want to reorder.
3. While pressing down on the left mouse button, move your mouse and drag the item to the new location in the queue. When you select an item with your mouse, you will see that it is highlighted to let you know that it is selected.
4. Release the mouse button at the new location for the print job. The job will be displayed at the new position.

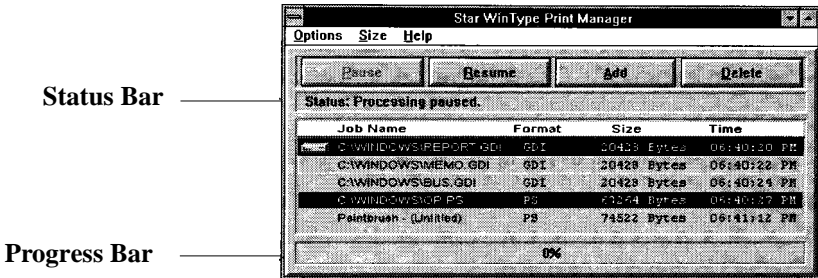
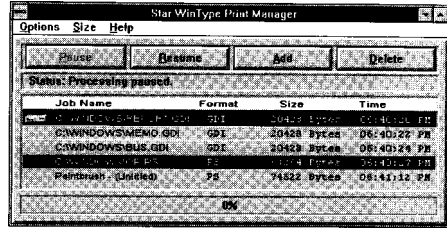

Status Bar

This shows whether the printer is printing or is ready to print. When printing, the status bar shows the page number currently being printed.

Progress Bar

The progress bar shows what percentage of your print job has been processed by the printer driver software on your computer. The print job will begin to print once the job has been processed.

Pause

This button lets you temporarily stop the current job. Once stopped, you can use the **Resume** button to continue printing, or you can cancel the print job by clicking on the **Delete** button.

Resume

This will allow you to continue printing the job that was paused.

Add

Add lets you include another print job at the end of the queue. The job selected must be stored on your hard disk to be displayed. The following section explains how to save documents you have created for printing with the **Star WinType Print Manager**.

Delete

If you want to cancel a print job, you can do so with this button. You can select any print job in the queue by clicking and highlighting the job with your mouse. Then click on **Delete** to eliminate it from the queue. To delete the job, click **OK**. Otherwise, click **Cancel**.

Printing to a file in the Windows Direct (GDI) and PCL modes

You can create print job files for specific printing formats regardless of the default printer setting and add them to the **Star WinType Print Manager** queue by following the steps below.

Note: The example steps below use the Write software application in Windows. Some applications don't necessarily include all of these steps.

Steps:

1. After you have created a document, you can save the file in the normal way you would for any application.
2. Click on the **Print** command from the file menu of your application.
3. Click on the **Setup** button.
Double-click either the **Star WinType GDI on WTGDI** or **Star WinType 4000 PCL on WTPCL**.
4. Click on the **Print to File** checkbox in the bottom left hand side of the **Print** dialog box.
5. Click **OK** to save your changes.

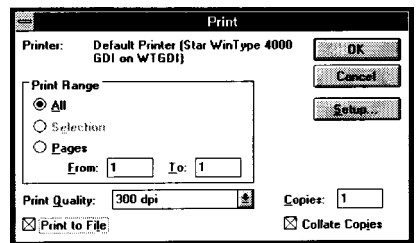
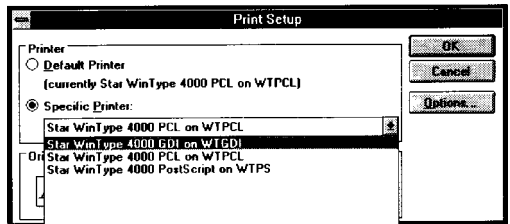

6. A dialog box like the one at right will appear on your display. Type the Output File Name for the document which you want to print from the **Star WinType Print Manager**.

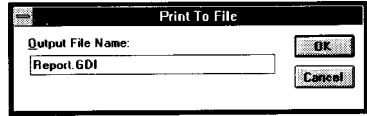

Give your file a name no longer than 8 characters.

If you selected the **Star WinType 4000 GDI on WTGDI**, your file name must end with **.GDI**.

If you selected the **Star WinType 4000 PCL on WTPCL**, your file name must end with **.PCL**.

7. Click **OK** to save your file.
 8. Close your application.
 9. Access the **Star WinType Print Manager** as described on pages 43 - 44.

10. Click on the **Pause** button.

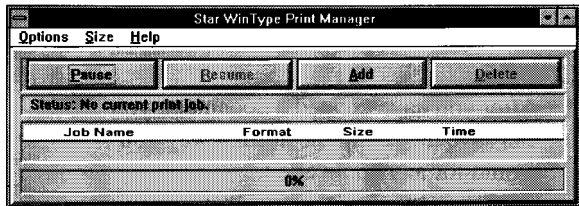

11. Click on the **Add** button.

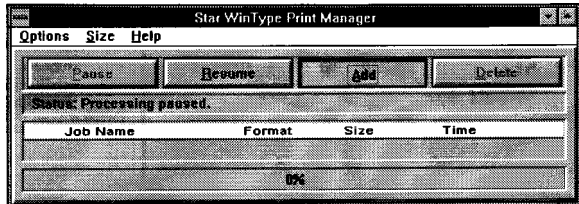

12. Click on the **File format Drop Down List Box** and select the format with which you just printed to file (GDI or PCL). You will find a list containing all of the files you have created with that specific printing format.

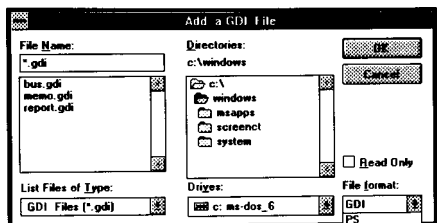

13. Click on the file that you want to print from the **File Name:** list and click **OK**.

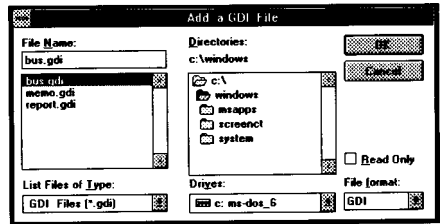

14. Your selection will appear in the queue of the **Star WinType Print Manager**.

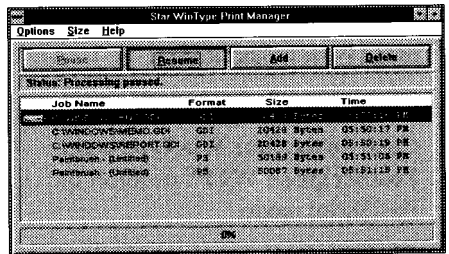

15. You can continue this process until you have finished adding to the list all of the files that you want to print.

16. Click the **Resume** button in the **Star WinType Print Manager** and all of the files you have selected will be printed.

Printing to an Encapsulated PostScript file in the PostScript mode

The steps for printing to file with the PostScript mode are basically the same as the Windows Direct (GDI mode). There are, however, some minor differences in the way you create an Encapsulated PostScript file for use with the **Star WinType Print Manager**. The following steps use "**Write**" as an example.

Steps:

1. After you have created a document, you can save your document in the normal way you would for any application.
2. Click on the **Print** command from the file menu of your application.
3. Click on the **Setup** button.
4. Click on the **Star WinType 4000 PostScript on WTPS** to select the PostScript mode.
5. Click on the **Setup** button in the **Print Setup** Screen.

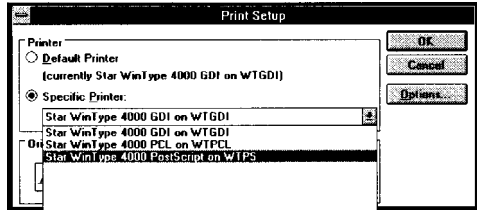

6. Click on the **Options** button
7. Click on **Encapsulated PostScript File** in the **Print To** section of the **Options** dialog box.

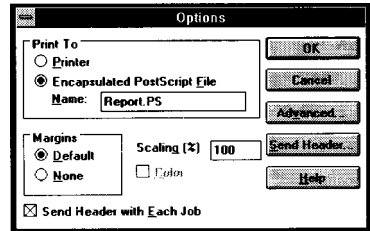

8. Give your file a name (no longer than 8 characters) followed by ".PS"
9. Follow **Steps 8 – 16** on pages 52 - 53.

10. Click **OK** to exit the **Options** window and to save your changes.
11. Click **OK** to exit the **Star WinType 4000 PostScript Setup** window and to save your printer changes.
12. Click **OK** to exit the **Print Setup** window.
13. Click **OK** to exit the **Print** window and to save your **.PS** file to your hard disk.
14. Follow **Steps 8 – 16** on pages 52 - 53.

Note: The steps explained above may vary in some applications. The steps for Printing to an Encapsulated PostScript file in the PostScript mode when using **Paintbrush**, for example, are slightly different. First click on **Print Setup** in the **File** menu to select the PostScript mode. Then click on the **Options** button. After doing that you can follow from **Step 5**.

Quitting the Star WinType Print Manager

Double-click on the Control-Menu box to quit the **Star WinType Print Manager**. Another way to do this is to press **Alt** and **F4**. Quitting Windows will also close the print manager.

Exiting before a print job has been completed

If you try to exit the print manager before you have completed the print jobs, the **Star WinType Print Manager** will display a message asking if you want to save the remaining print jobs.

If you select "**YES**," the print jobs will be saved and you can exit. When you start up the print manager the next time, you can resume printing the unfinished documents.

If you select "**NO**," all print jobs in the queue will be lost and you will exit. This has no effect on the file where the print jobs were created.

Selecting "**Cancel**" will cancel the exiting command and you will remain in the **WinType Print Manager** window.

Chapter 6 Star WinType Printer Status Display

The Star WinType Printer Status Display graphically displays the status of your Star WinType 4000 printer. It will let you know when something is printing and alert you to any errors that may occur when printing. It will display a warning or error message and graphically point to the problem area on the printer and give you instructions on how to fix the problem. In all three printing modes, you can choose whether or not to display the Print Status window when printing.

Caution: The **WinType Printer Status Display** is designed for Windows applications only. Turn this feature off when printing from a DOS application in PCL or PostScript modes.

Selecting the Printer Status Display - Windows Direct (GDI) mode

To setup the **WinType Printer Status Display** in the Windows Direct (GDI) mode when the WinType Print Manager is Off, follow the **Steps** below.

Steps:

1. Switch to the **Program Manager**.
2. Open the **Main** group by double-clicking on its icon.
3. Double-click on the **Control Panel** icon in the **Main** group.
4. Double-click on the **Printers** icon in the **Control Panel** window.

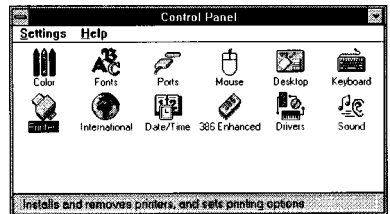

5. Double-click on **Star WinType 4000 GDI on WTGDI**.

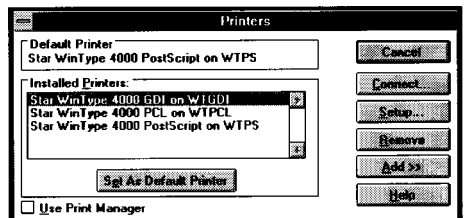

6. Click on the **Setup** button.

7. Click on the **Options** button.

The **Options** button will take you to the **Options** window where you can select the **Printing Status Options** described below.

As mentioned in Chapter 4, clicking the box marked **Display Status While Printing** will cause the printer to pop up the print status window whenever you print in the Windows Direct (GDI) mode. However, you cannot select this option if you have checked **Use WinType Print Manager**.

If you don't click this box, you only see this box when the printer encounters an error or during printer warm up and needs to inform you of a warning.

For example, when the printer has run out of paper you will receive a message that tells you to add paper.

If you put a check in the box marked **Beep When Print Job is Complete**, you will hear a beep whenever the printer has finished a print job which you have sent.

If you leave this box blank, the printer will beep only when an error occurs.

8. Click **OK** to exit the **Options** window and to save your changes.

9. Click **OK** to exit the **Setup** window.

10. Click on **Close** to exit the **Printers** window and to save your printer selection.

11. Click on **Settings** in the **Control Panel** menu and select **Exit** to exit the **Control Panel** window.

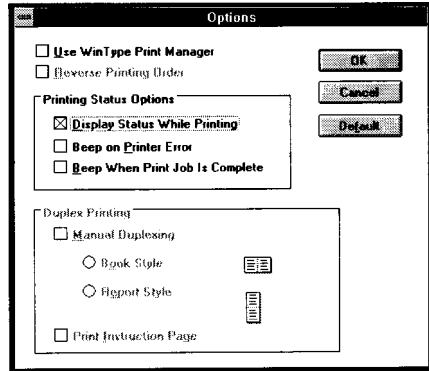
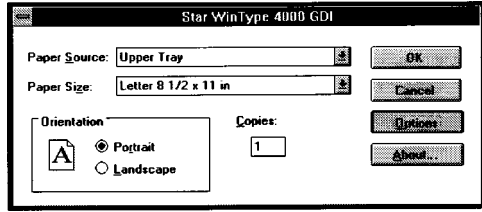

Selecting the Printer Status Display - PCL and PostScript modes

To setup the **Star WinType 4000 Printer Status Display** in the PCL and PostScript modes, and in the Windows Direct (GDI) mode when the **WinType Print Manager** is on, follow the **Steps** below.

Steps:

1. Open the **Star WinType Tools** group from the **Program Manager** by double-clicking on the **Star WinType Tools** group window.
2. Double-click on the **Star WinType Print Manager** icon.

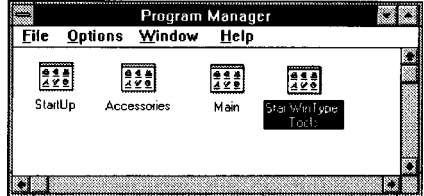

3. Click on the **Options** menu in the **Star WinType Print Manager**.
4. Click on **Display Print Status** with your mouse. This will cause the **Star WinType Printer Status Display** to be displayed whenever you print, either directly from an application or when you print using the **Star WinType Print Manager**.

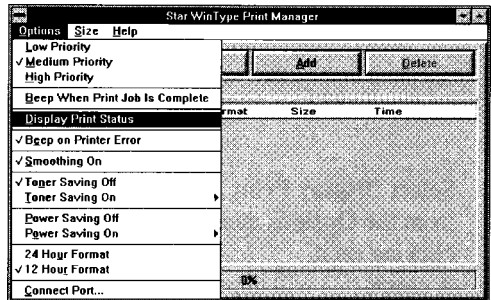

Caution: Do not select **Display Print Status** if you are printing from a DOS application in either PCL or PostScript modes.

5. You can also select from the **Star WinType Print Manager** whether to **Beep When Print Job is Complete**, or to **Beep on Printer Error** by clicking on these selections with your mouse.
6. To exit the **WinType Print Manager** and save your settings, click on the Control-Menu box in the upper left hand corner of the window.
7. Click on **Close**.

Accessing and viewing the Star WinType 4000 Printer Status Display

Steps:

1. Open the **Star WinType Tools** group from the **Program Manager** by double-clicking on the **Star WinType Tools** group icon.

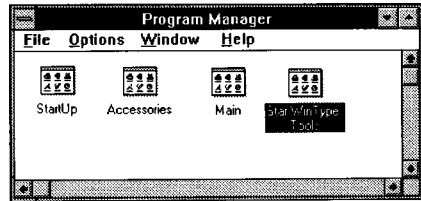

2. Double-click on the **Star WinType Print Manager** icon.

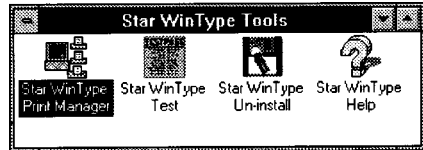

3. Select **Display Print Status** from the **Options** menu by clicking on it.
A check () will appear when the feature is turned on.

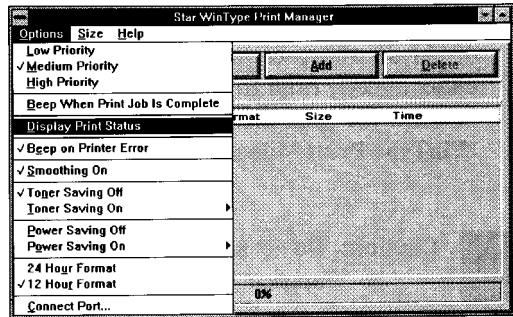

4. Reduce the size of the **Star WinType Print Manager** screen by clicking **Minimum** in the **Size** menu.

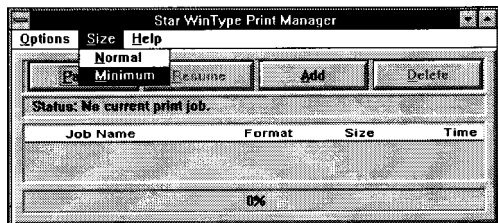

5. The **Star WinType Printer Status Display** screen will appear.
To view the **WinType Printer Status Display** at full size, click anywhere on the **Printer Status Display** Screen.
6. To exit the **WinType Printer Status Display** and to save your settings, click on the Control-Menu box in the upper left hand corner of the **Star WinType Print Manager** window.
7. Click on **Close**.

The following pages describe the various features of the **Star WinType 4000 Printer Status Display**.

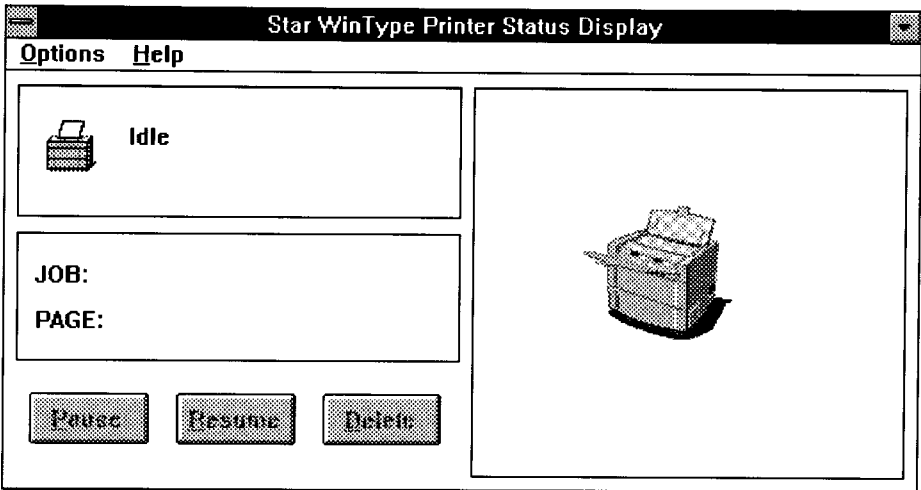

Please refer to the above illustration of the **Star WinType 4000 Printer Status Display** while we explain the features.

Options:
Animate Icon (Animate window)

This setting allows you to display an animated icon of your printer. This icon appears in the print status window and will provide you with real-time animation of the printer's status. If **Animate Icon** is checked, the printer icon will show paper being printed.

Note: The **Animate Icon** feature uses additional system memory. If your system is low on free memory, this feature should be turned off.

Help:

1. Contents

This gives a table of contents on the available subjects in the Help menu.

2. Search for Help On...

With this option, you can open a window which allows you to get information on this printer's features.

3. How to Use Help

This is a standard Windows Help guide to instruct users on how to access the Help menu.

4. About

This will give you information about the printer software version you are currently using.

Job

This displays the name of the application, file name and page number of the job currently being printed.

Picture of your printer (Status Display Message Window)

This displays a picture of your printer. If a problem should occur, an arrow will point to the problem area and provides step-by step instructions to solve the problem.

Status Display Messages

This window will show an error or status message. It will also tell you what to do for each error or warning message. Some of the possible messages include the following items.

Cover Open

Your printer's cover is open. Firmly close the printer's cover.

Duplex Printing

Duplex (double-sided) printing mode is enabled and the printer has finished printing on one side of your documents. In this case, follow the directions on the **Print Instruction** page to print on the other side. (See Chapter 4 Printing with the WinType 4000 for an explanation on duplex printing.)

Warming Up

Wait until the printer has finished warming up. The printer will begin to print automatically.

Paper Out

The printer has run out of paper. Add more paper to the upper paper tray. Click the **RESUME** button to start again.

Paper Jam

Paper has jammed inside the printer, making it impossible to continue printing. Open the printer's cover and remove the toner cartridge. Pull the jammed paper toward the front of the printer. Reinstall the toner cartridge and close the cover. For detailed information on clearing paper jams, refer to pages 67 - 69 in this manual.

This printer will start automatically once the jam has been cleared. In most cases, the printer will continue printing the rest of your document.

Power Off or Cable Problem

The printer driver software cannot access the printer. This error could be caused by one of the following.

1. The printer is Off
2. The printer's parallel cable is not plugged in properly.
3. A problem exists within the cable connection or the parallel cable is not good.

You need to verify if the printer is turned ON and that the left printer status lamp (Green LED) is lit or flashing. Check that the parallel cable is properly connected to the printer and the computer.

Printing

This message indicates that the printer is currently printing your document.

NV-RAM Error

This message indicates a possible problem with the printer's Nonvolatile RAM settings. Turn the printer off, then on again. If the problem does not clear, reinstall the WinType driver. If after reinstalling the WinType driver, the problem persists, contact your dealer or Customer Support.

Fuser Abnormality

This message indicates a possible problem with the printer's fuser assembly. Turn the printer off, then on again. If the problem persists, contact your dealer or Customer Support.

Scanner Abnormality

This message indicates a possible problem with the printer's scanner assembly. Turn the printer off, then on again. If you see this message persistently, then something is wrong with the printer's engine. Call your dealer or Customer Support.

EP (Toner) cartridge missing

This message indicates that the toner cartridge has not been installed or is not installed properly. Open the printer's front cover, install or reinstall the toner cartridge and close the cover.

Pause

This button lets you pause the print job. You can pause printing, for example, to delete the print job from the print manager. If this selection is displayed in gray, the option is not currently available.

Resume

The **Resume** button lets you continue the print job you have just paused or to begin again after recovering from an error. If this selection is displayed in gray, the option is not currently available.

Delete

This button will delete the current print job. You must always pause the print job before you delete it. You can also delete a stopped print job. For example, you can delete a job that has stopped when the printer ran out of paper. If this selection is displayed in gray, the option is not currently available.

Chapter 7 Maintenance & troubleshooting —

Your printer is a reliable, precisioned instrument. It was built with care and should, if used with care, perform at its finest and serve you well for a long time. However, like any piece of equipment, there may be times when it may not perform as you had expected. In this chapter, we would like to provide you with simple guidelines on the proper maintenance and troubleshooting that will keep your printer in fine working condition.

Maintaining your printer

Because the toner cartridge is the most important part of your printer, its maintenance should begin with the proper handling of the toner cartridge. The toner cartridge contains a photosensitive drum and toner. Damage to the cartridge will affect print quality, so observe the following guidelines when handling.

Handling of the toner cartridge

- Do not expose the toner cartridge to direct sunlight or strong room light.
- When removed from the printer, always keep the toner cartridge in its original packaging or wrapped in a thick cloth to protect it from light.
- When moving the toner cartridge from a cold environment to a warmer one, let it adjust to the new temperature for at least one hour before installation.
- Do not stand the toner cartridge on end or with its label facing downward.
- Never disassemble the toner cartridge.
- If toner gets on your hands or clothing, wash it off immediately.
- Do not unpack the toner cartridge until you are ready to install it. If it is already unpacked, keep it in its original aluminum wrapping.
- Store the toner cartridge in a stable environment. (See Chapter 8 Reference information)
- **Never** store the toner cartridge on end or upside down; in direct sunlight or strong room light; near cathode ray tube (CRT) displays or floppy diskettes or within the reach of children.
- **Always** replace the toner cartridge following the procedures described on pages 2 — 4.

Note: The toner cartridge has a shelf life of approximately 2 years from the time of manufacturing.
Toner cartridges for the Star WinType 4000 can print more than 4,000 pages of A4 size or Letter size pages with 5% covering with the **Toner Save** feature off. Printing large quantities of graphic intense documents will shorten the toner cartridge's life span.

Cleaning your printer

This printer has been designed to be maintenance-free. For that reason, only a minimum of cleaning is needed. Other than maintaining the outer appearance of the printer, you may need to clean the output port window, which is explained below. To clean the outer surface of the printer, use a dry soft cloth to wipe off any dirt or stains.

If the printer's surface becomes very dirty, wipe it with a cloth moistened in a dilute mild soap. Wipe the printer dry with a dry, soft cloth.

Caution: Never use solvents, such as benzene, or cleaners to clean any part of the printer.

Cleaning the output port window

You may need to clean the laser output port window if you encounter any print quality problems like faded print or missing characters. If you do, follow the steps below.

Steps:

1. Turn the printer power switch to the OFF position [O] and close both the upper tray and output tray.

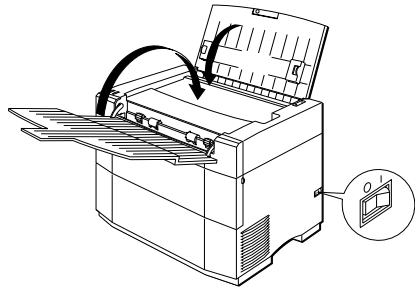

2. Disconnect the power cord from the wall outlet and from the printer socket in the back of the printer.

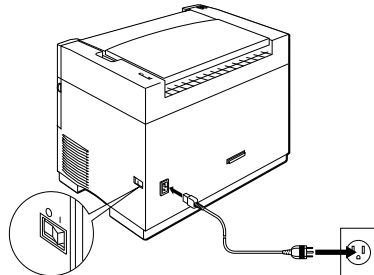

3. Remove the toner cartridge.
(Reverse the steps on pages 2 – 4)

Note: Always place the toner cartridge in its original, aluminized packaging or wrap it securely in a thick cloth to prevent exposure to light.

Warning: The fuser area, located in the upper front part of the printer, is extremely hot. Be especially careful not to touch any part of the fuser.

Warning: The drive motor becomes very hot after extended periods of printing. Be careful not to touch any metal part of the drive motor.

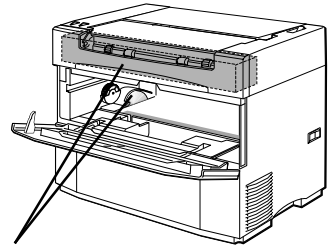

The fuser and drive motor are extremely hot. Do not touch this area.

4. Wipe the laser output port window with a dry, soft, lint-free cloth. The window is located in front of the long orange label in the center of the toner cartridge compartment.

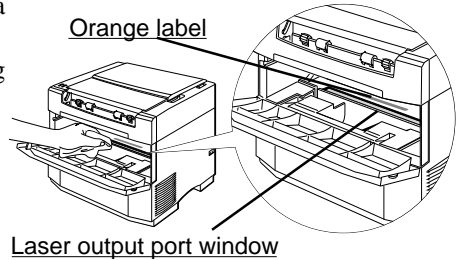

Note: Do not use tissue paper to wipe the laser output port window as this may leave paper fibers on the window.

5. Reinstall the toner cartridge. (Follow the **Steps** described on pages 2—4.)

Clearing paper jams

This printer's feeding mechanism is designed to be jam-free. However, you should observe the following steps should a paper jam occur and the **Error LED** is lit.

Caution: Never pull paper out of the toner cartridge in the reverse direction of the paper feed mechanism because this can damage the photosensitive drum.

Steps:

1. Remove all printed material from the output and paper trays and close them.

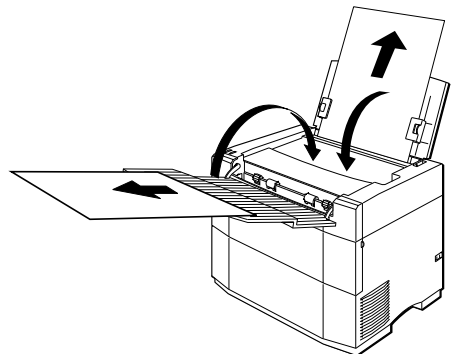

2. Face the front of the printer and flip open the front door using both hands.

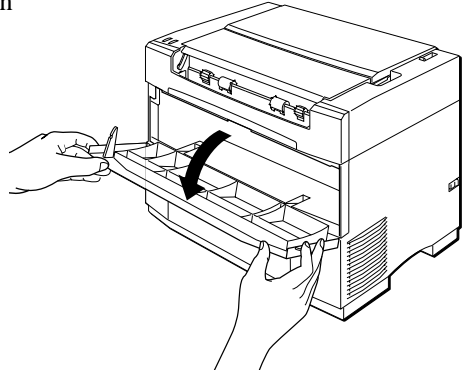

3. Gently rest one hand on the top of the printer, grasp the toner cartridge by its molded center grip with the other hand and pull upward until the cartridge unlocks and releases.

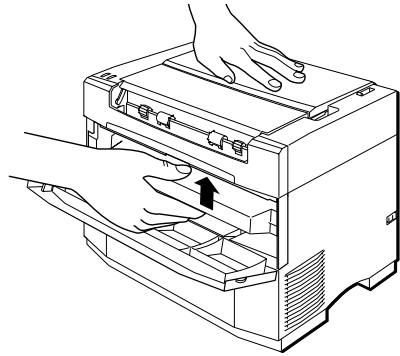

Warning: The fuser is located in the upper front part of the printer and it is extremely hot. Be especially careful not to touch any part of the fuser area.

Warning: The drive motor becomes very hot after extended periods of printing. Do not touch the driver motor; note the warning label located on the back of the drive motor

Caution: Do not press too hard on the top of the printer because this may damage the cover or trays.

4. Rotate the toner cartridge slightly downward until it is level. Slide it out of the printer.

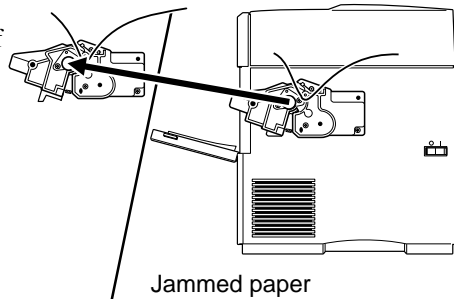

Note: The toner cartridge will not slide smoothly unless it is level. Paper may be caught in the toner cartridge feeding mechanism making it difficult to remove the cartridge. Pull firmly to draw the paper out with the cartridge.

5. If the jammed paper comes out with the toner cartridge, draw the paper out of the cartridge in the normal feeding direction.

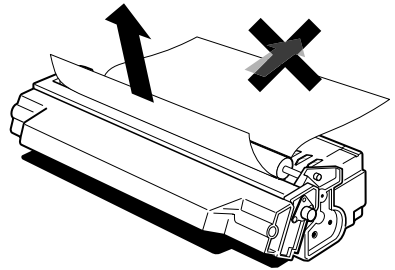

Caution: Never pull paper out of the toner cartridge in the reverse feeding direction of the paper feeding mechanism because this can damage the photosensitive drum.

6. If the paper does not come out with the toner cartridge, look inside the printer. If you can see the jammed paper inside the printer, draw the paper out through the front of the printer.

Warning: The fuser is located in the upper front part of the printer and it is extremely hot. Be especially careful not to touch any part of the fuser area when pulling out the jammed paper.

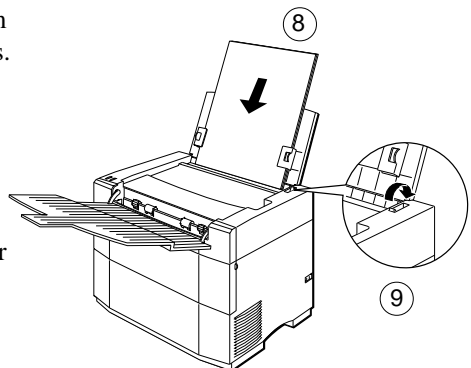

7. If the jammed paper is not visible inside the printer, the jam is in the feeder section. Move the paper release lever to the release position. Remove the stack from the feeder and pull out the jammed sheets.
8. Reload the stack of paper into the upper paper tray (See pages 12 – 14).
9. Move the paper release lever toward the rear of the printer.
10. After clearing the jam, reinstall the toner cartridge and close the front door. (See the explanation on pages 2 — 4.)







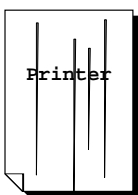

Note: Use the above procedures for other print media jams.

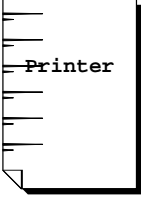

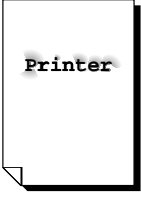
Troubleshooting: Solving print quality problems

Below is a list some of the problems that you may encounter with this printer. Ordinarily, you can easily remedy the situation yourself. However, if the problem persists, call your authorized Star Micronics service center or our customer service department for assistance. The addresses and telephone numbers where you can contact these people are listed in the back of this manual.

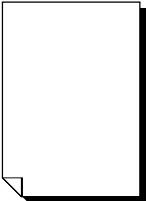
Symptom	Possible Cause	Action
 <p>Faded print</p>	The print media is moist	Remove the moist media and load new, dry media. Refer to "Loading paper" pages 12 — 14
	The laser output port window is dirty.	Clean the output port window. Refer to "Cleaning the output port window" pages 66 — 67.
	The toner cartridge is low on toner	Replace the toner cartridge. Refer to "Installing the toner cartridge" pages 2 — 4.
	The toner cartridge is damaged.	Replace the toner cartridge. Refer to "Installing the toner cartridge" pages 2 — 4.
 <p>Black dots</p>	The print media is outside the recommended specifications.	Use recommended print media. Refer to "Selecting print media" page 11.
	The toner cartridge is damaged.	Replace the toner cartridge. Refer to "Installing the toner cartridge" pages 2 — 4.
 <p>Vertical black streaks</p>	The toner cartridge is damaged.	Replace the toner cartridge. Refer to "Installing the toner cartridge" pages 2 — 4.
	The laser output port is dirty.	Clean the output port window. Refer to pages 66 – 67.

Symptom	Possible Cause	Action
 <p>Repetitive defects</p>	The paper path is dirty.	Print out several blank sheets.
	The toner cartridge is damaged.	Replace the toner cartridge. Refer to "Installing the toner cartridge" pages 2 — 4.
 <p>Character voids</p>	The print media is outside the recommended specifications.	Use recommended print media. Refer to "Selecting print media" page 11.
	The laser output port window is dirty.	Clean the output port window. Refer to "Cleaning the output port window" pages 66— 67.
	The toner cartridge is damaged.	Replace the toner cartridge. Refer to "Installing the toner cartridge" pages 2 — 4.
 <p>Toner smears when rubbed</p>	The print media is moist	Remove the moist media and load new, dry media. Refer to "Loading paper" pages 12 — 14
	The print media is outside the recommended specifications.	Use recommended print media. Refer to "Selecting print media" page 11.
 <p>Black page</p>	The toner cartridge is damaged.	Replace the toner cartridge. Refer to "Installing the toner cartridge" pages 2 — 4.

Symptom	Possible Cause	Action
 <p data-bbox="141 608 269 635">Blank page</p>	<p data-bbox="359 156 665 213">The toner cartridge's sealing tape is not pulled out.</p>	<p data-bbox="717 156 975 373">Replace the toner cartridge and pull out the sealing tape. Then reinstall the cartridge. Refer to "Installing the toner cartridge" pages 2 — 4.</p>
	<p data-bbox="359 395 661 453">The printer fed two or more sheets at a time.</p>	<p data-bbox="717 395 1001 517">Fan the print media before loading. Refer to "Loading paper" pages 12 — 14.</p>
	<p data-bbox="359 544 665 635">A jam error occurred (If the Error LED indicator is lit.)</p>	<p data-bbox="717 544 986 761">Check for a paper jam. Refer to "Clearing paper jams" pages 67 — 68. Make sure that the paper release lever is in the locked position before printing.</p>
	<p data-bbox="359 783 661 841">The toner cartridge is out of toner</p>	<p data-bbox="717 783 978 904">Replace the toner cartridge. Refer to "Installing the toner cartridge" pages 2 — 4.</p>
	<p data-bbox="359 922 698 963">The toner cartridge is damaged.</p>	<p data-bbox="717 922 978 1043">Replace the toner cartridge. Refer to "Installing the toner cartridge" pages 2 — 4.</p>
 <p data-bbox="113 1367 300 1394">Partial deletions</p>	<p data-bbox="359 1066 628 1107">The print media is moist.</p>	<p data-bbox="717 1066 990 1187">Remove the moist media and load new, dry media. Refer to "Loading paper" pages 12 — 14.</p>
	<p data-bbox="359 1220 642 1310">The print media is outside the recommended specifications.</p>	<p data-bbox="717 1220 983 1342">Use recommended print media. Refer to "Selecting print media" page 11.</p>
	<p data-bbox="359 1364 698 1406">The toner cartridge is damaged.</p>	<p data-bbox="717 1364 978 1485">Replace the toner cartridge. Refer to "Installing the toner cartridge" pages 2 — 4.</p>

Symptom	Possible Cause	Action
 <p data-bbox="124 363 359 389">Wrinkled or blurred</p>	<p data-bbox="396 156 714 245">The print media is outside the recommended specifications.</p>	<p data-bbox="759 156 1020 277">Use recommended print media. Refer to "Selecting print media" page 11.</p>
	<p data-bbox="396 300 714 325">The print media is moist.</p>	<p data-bbox="759 300 1020 421">Remove the most media and load new, dry media. Refer to "Loading paper" pages 12 — 14.</p>
 <p data-bbox="124 683 359 708">Vertical deletions</p>	<p data-bbox="396 443 714 501">The toner cartridge is low on toner</p>	<p data-bbox="759 443 1020 564">Replace the toner cartridge. Refer to "Installing the toner cartridge" pages 2 — 4.</p>
	<p data-bbox="396 587 714 612">The toner cartridge is damaged.</p>	<p data-bbox="759 587 1020 708">Replace the toner cartridge. Refer to "Installing the toner cartridge" pages 2 — 4.</p>
	<p data-bbox="396 730 714 756">The laser output port is dirty.</p>	<p data-bbox="759 730 1020 820">Clean the output port window. Refer to pages 66 – 67.</p>

Other mechanical problems

This is to provide you with a list of other possible problems and their easy remedy.

The front door will not shut

Remove and reinstall the toner cartridge. Refer to "Installing the toner cartridge" on pages 2 — 4.

The Error LED indicator is lit and the printer will not print

- Make sure that the front door is properly shut.
- Remove and reinstall the toner cartridge. Refer to "Installing the toner cartridge" on pages 2 — 4.
- Check for a paper jam. Refer to "Clearing paper jams" on pages 67 — 68.
- If the **Error LED** indicator remains lit, move the paper release lever to the release position (toward the front of the printer), remove all print media from the feeder tray and then turn the power OFF and ON again. If, after performing all of these procedures, the **Error LED** indicator still remains lit, contact an authorized Star Micronics service center.

Chapter 8 Reference information

Specifications

Engine

Printing process	Electrophotographic
Resolution	300 X 300 dpi (Smoothing off) 600 dpi class (Smoothing on)
Exposure	Semiconductor laser beam scanning
Fixing	Thermal fusing by heated rollers

Printing speed

Warm-up time	45 seconds or less after power on at 22°C (72°F) (115 volts or 220 volts)
Time for first print	20.5 seconds for Letter paper 21.1 seconds for A4 paper
Continuous printing speed	Min. 4 pages per minute for Letter or A 4 size paper
Printable area	Guaranteed printing requires a margin of 4 mm from edge of the paper.

Paper feed

Input tray	Capacity: 100 sheets of standard paper or 30 overhead (OHP) transparencies or 30 label sheets or 10 envelopes Paper weight: 60 g/m ² (16 lb.) • 135 g/m ² (36 lb.)
Output tray	Face down Capacity: Approximately 50 sheets of standard paper

Printing materials

Standard paper	XEROX 4024 DP 20 lb 8.5" X 11" cut sheet paper (US)
Special printing materials	OHP film: 8.5" X 11" XEROX, PN 3R2780 (US) A4 XEROX, PN 3R91330 (Europe) Label: 8.5" X 11" XEROX, PN 3R4469 (US) A4 XEROX, PN 3R97408 (Europe) Envelope: Com-10 Monroe Brand Monarch Monroe Brand

Toner cartridge

	The toner cartridge consists of the OPC drum, the developing roller and blades, primary charge roller, the drum cleaner and high definition black toner.										
Toner save mode	Off/Dark/Medium/Light										
	<table><thead><tr><th><u>Mode</u></th><th><u>Yield</u></th></tr></thead><tbody><tr><td>Off</td><td>Approx. 4000 pages</td></tr><tr><td>Dark</td><td>Approx. 5000 pages</td></tr><tr><td>Medium</td><td>Approx. 5700 pages</td></tr><tr><td>Light</td><td>Approx. 8000 pages</td></tr></tbody></table>	<u>Mode</u>	<u>Yield</u>	Off	Approx. 4000 pages	Dark	Approx. 5000 pages	Medium	Approx. 5700 pages	Light	Approx. 8000 pages
<u>Mode</u>	<u>Yield</u>										
Off	Approx. 4000 pages										
Dark	Approx. 5000 pages										
Medium	Approx. 5700 pages										
Light	Approx. 8000 pages										

Mean printing life

Starter cartridge: 4000 sheets given a 5% coverage life
Replacement cartridge: 4000 sheets given a 5% coverage life

Power specifications

Input line voltage/
frequency

For US Voltage Frequency
Min.: 90V 47Hz
Normal: 100/120V 50/60Hz
Max.: 132V 63Hz

For Europe and Asia/Pacific

 Voltage Frequency
Min.: 198V 47Hz
Normal: 220/240V 50/60Hz
Max.: 264V 63Hz

Power consumption

Maximum power consumption at warming-up and printing is as follows
100/120V Less than 400W (less than 3A)
220/240V Less than 400W (less than 2A)

Environmental specifications

Temperature, humidity
and altitude

Energy Star Compliant
Print engine with toner cartridge:
 Operating: 5 – 35°C (41 – 95°F) at 15 – 85% RH
 (no condensation)
 Non-operating: 20 – 40°C (60 – 104°F) at 5 – 95% RH
 (no condensation)
 0 – 2,500 meters (0 – 8,200 feet)
Print engine without toner cartridge
 Non-operating: 20 – 40°C (60 – 104°F) at 5 – 95% RH
 (no condensation)
 0 – 15,000 meters (0 – 49,200 feet)

Acoustic noise

Printing: 48 dB (A) or less
Warm up: 38 dB (A) or less
In accordance with ISO 7779

Dust emission
concentration:

Less than 0.1mg/m³
Measured in accordance with Mass Measurements Method

Reliability specifications

MPBF	Recommended usage: Average 2,000 pages per month Maximum 10,000 in any one month MPBF: 60,000 pages
MTTR	Within 30 minutes
Jam ratio	1/1000 using recommended paper 1/100 using special printing materials
Double feed ratio	1/1000 using recommended paper 1/100 using special printing materials
Life	100,000 pages or 5 years
Dimensions	330mm X 235mm X 265mm (13.0 in. X 9.25 in. X 10.4 in.)
Weight	6.5 kg. (14.3 lbs.) without toner cartridge 7.5 kg. (16.5 lbs.) with toner cartridge

Controller

I/F	High speed bi-directional parallel interface
Panel	2 LED lamps (Ready and Error)

Software

Windows Direct (GDI) mode	Provides fast, WYSIWYG output for Windows applications
PCL mode	Provides compatibility with the popular printer languages used in the LaserJet IIP. Both Windows applications and DOS applications running under Windows can use PCL emulation mode for printing.
PostScript mode	Provides compatibility with the sophisticated PostScript language. Both Windows applications and DOS applications running under Windows can use PostScript emulation mode for printing.

Paper size

Paper size in GDI mode	A4, Letter, Legal, A5, Executive, B5, Com 10, C5, DL, Monarch
Paper size in PCL4 emulation	A4, Letter, Legal, Executive, Com 10, C5, DL, Monarch
Paper size in PostScript emulation mode	A4, Letter, Legal, A5, Executive, B5, Com 10, C5, DL, Monarch

Fonts

13 Original Windows 3.1 TrueType Fonts

<i>Arial</i>	<i>Arial Bold</i>
<i>Arial Italic</i>	<i>Arial Bold Italic</i>
<i>Courier New</i>	<i>Courier New Bold</i>
<i>Courier New Italic</i>	<i>Courier New Bold Italic</i>
<i>Times New Roman</i>	<i>Times New Roman Bold</i>
<i>Times New Roman Italic</i>	<i>Times New Roman Bold Italic</i>
<i>Συμβολ (Symbol)</i>	

Additional TrueType fonts

35 TrueType Fonts (on diskette)

American Text	Broadway
<i>Brush 445</i>	Caslon Openface
CloisterBlack	<i>Commercial Script</i>
Cooper Blk	DAVIDA BB
DemCasual	ENGRAVERSROMAN
EXOTIC350DMBd	Freefrm 721 Blk
<i>Freeshand 521</i>	HandelGothic
Hobo	Humanist 521 XBD
Impress	<i>Kaufmann</i>
OCR-A	OldDreadfulM.7
Onyx	Orbit-B
<i>Parisian</i>	<i>Park Avenue</i>
Playbill	PTBarnum
Raleigh DmBd	Schadow BlkCn
Seagull Hv	SHOTGUN
Tango	UniversityRoman
VAGRounded	Vineta
Windsor	

13 Original PostScript Fonts Substituted as TrueType Fonts

PostScript Mode

Original PostScript Font

Helvetica
Helvetica Bold
Helvetica Oblique
Helvetica BoldOblique
Courier
Courier Bold
Courier Oblique
Courier BoldOblique
Times Roman
Times Roman Bold
Times Roman Oblique
Times Roman BoldOblique
Symbol

TrueType Substitute

Arial
Arial Bold
Arial Italic
Arial BoldItalic
CourierNew
CourierNew Bold
CourierNew Italic
CourierNew BoldItalic
TimesNewRoman
TimesNewRoman Bold
TimesNewRoman Italic
TimesNewRomanBoldItalic
Symbol

PCL Mode
14 Bitmapped Fonts

Courier, 10 point, 12 pitch, regular, Bold and Italic
Courier, 12 point, 10 pitch, regular, Bold and Italic
Line Printer, 8.5 point, 16.66 pitch, Regular

Character tables for PCL mode

This section provides charts for the character sets used with fonts in LaserJet IIP PCL emulation.

Includes ASCII and Roman Extension Symbol Set

HEX	0	1	2	3	4	5	6	7	8	9	A	B	C	D	E	F	
0	<NUL>	<DLE>		0	@	P	`	p					—	â	Å	Á	Þ
1	<SOH>	<DC1>	!	1	A	Q	a	q			À	Ý	ê	î	Ã	þ	
2	<STX>	<DC2>	"	2	B	R	b	r			Â	Ÿ	ë	ï	ä	·	
3	<ETX>	<DC3>	#	3	C	S	c	s			Ã	°	ô	ø	å	µ	
4	<EOT>	<DC4>	\$	4	D	T	d	t			Ä	ç	á	é	í	¼	
5	<ENQ>	<NAK>	%	5	E	U	e	u			È	Ç	ê	í	ï	½	
6	<ACK>	<SYN>	&	6	F	V	f	v			Ê	Ñ	ó	ø	Ï	¾	
7	<BEL>	<ETB>	'	7	G	W	g	w			Ë	Ñ	ñ	ú	æ	—	
8	<BS >	<CAN>	(8	H	X	h	x			Ì	ˆ	î	à	Ä	Ò	
9	<HT >)	9	I	Y	i	y			Í	ˆ	ï	à	È	Ö	
A	<LF >	<SUB>	*	:	J	Z	j	z			Î	ˆ	ª	è	Ì	ø	
B	<VT >	<ESC>	+	;	K	[k	{			Ï	ˆ	£	ù	Ö	«	
C	<FF >	<FS >	,	<	L	\	l				Û	ˆ	¥	ä	É	■	
D	<CR >	<GS >	-	=	M]	m	}			Ü	ˆ	§	ë	Ï	»	
E	<SO >	<RS >	.	>	N	^	n	~			Ù	ˆ	š	ö	Û	±	
F	<SI >	<US >	/	?	O	_	o	⌘			Ú	ˆ	ç	ü	Û		

ECMA-94 Latin 1 Symbol Set

HEX	0	1	2	3	4	5	6	7	8	9	A	B	C	D	E	F	
0	<NUL>	<DLE>		0	@	P	`	p					°	À	Ð	à	ø
1	<SOH>	<DC1>	!	1	A	Q	a	q			ı	±	À	Ñ	Ò	á	ñ
2	<STX>	<DC2>	"	2	B	R	b	r			ı	²	Á	Ñ	Ò	â	ò
3	<ETX>	<DC3>	#	3	C	S	c	s			ı	³	Ã	Ó	Ô	ã	ó
4	<EOT>	<DC4>	\$	4	D	T	d	t			ı	´	Ä	Ô	Õ	ä	ô
5	<ENQ>	<NAK>	%	5	E	U	e	u			ı	µ	Å	Õ	Ö	å	ö
6	<ACK>	<SYN>	&	6	F	V	f	v			ı	¶	Æ	Ö	Ø	æ	ø
7	<BEL>	<ETB>	'	7	G	W	g	w			ı	·	Ç	×	Ø	ç	÷
8	<BS >	<CAN>	(8	H	X	h	x			ı	ˆ	È	×	Ø	è	ù
9	<HT >)	9	I	Y	i	y			ı	ˆ	É	×	Ø	é	ú
A	<LF >	<SUB>	*	:	J	Z	j	z			ı	ˆ	Ê	×	Ø	ê	û
B	<VT >	<ESC>	+	;	K	[k	{			ı	ˆ	Ë	×	Ø	ë	ü
C	<FF >	<FS >	,	<	L	\	l				ı	ˆ	Ì	×	Ø	ì	ü
D	<CR >	<GS >	-	=	M]	m	}			ı	ˆ	Í	×	Ø	í	ý
E	<SO >	<RS >	.	>	N	^	n	~			ı	ˆ	Î	×	Ø	î	ÿ
F	<SI >	<US >	/	?	O	_	o	⌘			ı	ˆ	Ï	×	Ø	ï	ÿ

PC-8 Symbol Set

HEX	0	1	2	3	4	5	6	7	8	9	A	B	C	D	E	F
0	<NUL>	▶		0	@	P	`	p	Ç	É	á	⋮	⌌	⌌	α	≡
1	☉	◀	!	1	A	Q	a	q	Û	æ	í	⋮	⌌	⌌	β	≡
2	●	‡	"	2	B	R	b	r	é	Æ	ó	⋮	⌌	⌌	Γ	≡
3	♥	!!	#	3	C	S	c	s	ê	ö	ú	⋮	⌌	⌌	π	≡
4	♦	‡	\$	4	D	T	d	t	ä	ö	ñ	⋮	⌌	⌌	Σ	≡
5	♣	‡	%	5	E	U	e	u	å	ö	ñ	⋮	⌌	⌌	σ	≡
6	♠	‡	&	6	F	V	f	v	ç	ö	ñ	⋮	⌌	⌌	μ	≡
7	●	‡	'	7	G	W	g	w	ç	ü	ñ	⋮	⌌	⌌	τ	≡
8	◻	‡	(8	H	X	h	x	è	ÿ	ö	⋮	⌌	⌌	θ	≡
9	○	‡)	9	I	Y	i	y	ë	ÿ	ö	⋮	⌌	⌌	Φ	≡
A	◼	‡	*	:	J	Z	j	z	è	ÿ	ö	⋮	⌌	⌌	Ω	≡
B	♀	‡	+	;	K	[k	{	è	ÿ	ö	⋮	⌌	⌌	δ	≡
C	♂	‡	,	<	L	\	l		è	ÿ	ö	⋮	⌌	⌌	∞	≡
D	♫	‡	-	=	M]	m	~	è	ÿ	ö	⋮	⌌	⌌	φ	≡
E	♫	▲	.	>	N	^	n	ˆ	è	ÿ	ö	⋮	⌌	⌌	ε	≡
F	*	▼	/	?	O	_	o	◊	À	ä	å	⋮	⌌	⌌	∩	≡

PC-8 D/N (Danish/Norwegian) Symbol Set

HEX	0	1	2	3	4	5	6	7	8	9	A	B	C	D	E	F
0	<NUL>	▶		0	@	P	`	p	Ç	É	á	⋮	⌌	⌌	α	≡
1	☉	◀	!	1	A	Q	a	q	Û	æ	í	⋮	⌌	⌌	β	≡
2	●	‡	"	2	B	R	b	r	é	Æ	ó	⋮	⌌	⌌	Γ	≡
3	♥	!!	#	3	C	S	c	s	ê	ö	ú	⋮	⌌	⌌	π	≡
4	♦	‡	\$	4	D	T	d	t	ä	ö	ñ	⋮	⌌	⌌	Σ	≡
5	♣	‡	%	5	E	U	e	u	å	ö	ñ	⋮	⌌	⌌	σ	≡
6	♠	‡	&	6	F	V	f	v	ç	ö	ñ	⋮	⌌	⌌	μ	≡
7	●	‡	'	7	G	W	g	w	ç	ü	ñ	⋮	⌌	⌌	τ	≡
8	◻	‡	(8	H	X	h	x	è	ÿ	ö	⋮	⌌	⌌	θ	≡
9	○	‡)	9	I	Y	i	y	ë	ÿ	ö	⋮	⌌	⌌	Φ	≡
A	◼	‡	*	:	J	Z	j	z	è	ÿ	ö	⋮	⌌	⌌	Ω	≡
B	♀	‡	+	;	K	[k	{	è	ÿ	ö	⋮	⌌	⌌	δ	≡
C	♂	‡	,	<	L	\	l		è	ÿ	ö	⋮	⌌	⌌	∞	≡
D	♫	‡	-	=	M]	m	~	è	ÿ	ö	⋮	⌌	⌌	φ	≡
E	♫	▲	.	>	N	^	n	ˆ	è	ÿ	ö	⋮	⌌	⌌	ε	≡
F	*	▼	/	?	O	_	o	◊	À	ä	å	⋮	⌌	⌌	∩	≡

PC-850 Symbol Set

HEX	0	1	2	3	4	5	6	7	8	9	A	B	C	D	E	F
0	<NUL>	▶		0	@	P	`	p	Ç	É	á	⋮	⌒	ø	Ó	-
1	☉	◀	!	1	A	Q	´	a	ú	æ	í	⋮	⌒	ø	Ó	±
2	☉	↑	!"	2	B	R	´	b	é	Æ	ó	⋮	⌒	ø	Ó	±
3	♥	!!	#"	3	C	S	´	c	ê	ø	ó	⋮	⌒	ø	Ó	±
4	♦	\$\$\$	#\$	4	D	T	´	d	â	ö	ó	⋮	⌒	ø	Ó	±
5	♣	\$%	\$%	5	E	U	´	e	ã	ö	ó	⋮	⌒	ø	Ó	±
6	♠	-	&	6	F	V	´	f	ä	û	ã	⋮	⌒	ø	Ó	±
7	•	↑	'	7	G	W	´	g	ç	ù	ä	⋮	⌒	ø	Ó	±
8	☐	↑	(8	H	X	´	h	ê	ÿ	ö	⋮	⌒	ø	Ó	±
9	○	↓)	9	I	Y	´	i	ë	ÿ	ö	⋮	⌒	ø	Ó	±
A	◐	→	*	A	J	Z	´	j	ë	ÿ	ö	⋮	⌒	ø	Ó	±
B	♀	↑	+	B	K	[´	k	ï	ÿ	ö	⋮	⌒	ø	Ó	±
C	♂	↑	<	C	L	\	´	l	î	ÿ	ö	⋮	⌒	ø	Ó	±
D	♪	↑	,	D	M]	´	m	ï	ÿ	ö	⋮	⌒	ø	Ó	±
E	♪	↑	-	E	N	^	´	n	ï	ÿ	ö	⋮	⌒	ø	Ó	±
F	*	↓	/	F	O	_	´	o	ä	ÿ	ö	⋮	⌒	ø	Ó	±

ISO Substitution Table

ISO	Name	ID	HEXADECIMAL CHARACTER EQUIVALENTS															
			23	24	40	5B	5C	5D	5E	60	7B	7C	7D	7E				
6	ASCII	0U	#	\$	@	[\]	^	`	{		}	~				
2	ISO IRV*	2U	#	¤	@	[\]	^	`	{		}	~				
4	ISO United Kingdom	1E	£	\$	@	[\]	^	`	{		}	~				
25	ISO French*	0F	£	¢	à	°	ç	ç	ç	ç	é	ù	è	è	è	è		
69	ISO French German*	1F	£	¢	à	°	ç	ç	ç	ç	é	ù	è	è	è	è		
21	ISO German	0G	£	¢	à	°	ç	ç	ç	ç	é	ù	è	è	è	è		
15	ISO Italian	1G	#	¤	@	[\]	^	`	{		}	~				
14	ISO Italian	0I	£	¢	à	°	ç	ç	ç	ç	é	ù	è	è	è	è		
14	JIS ASCII*	0K	#	¤	@	[\]	^	`	{		}	~				
57	ISO Chinese*	2K	#	¤	@	[\]	^	`	{		}	~				
10	ISO Swedish*	3S	#	¤	@	[\]	^	`	{		}	~				
11	ISO Swedish names Spanish*	0S	#	¤	@	[\]	^	`	{		}	~				
17	ISO Spanish	1S	#	¤	@	[\]	^	`	{		}	~				
17	ISO Spanish	2S	£	¢	@	[\]	^	`	{		}	~				
85	ISO Spanish:*	6S	#	¤	@	[\]	^	`	{		}	~				
16	ISO Portuguese*	4S	#	¤	@	[\]	^	`	{		}	~				
84	ISO Portuguese:*	5S	#	¤	@	[\]	^	`	{		}	~				
60	ISO Norwegian v1	0D	#	¤	@	[\]	^	`	{		}	~				
61	ISO Norwegian v2*	1D	\$	\$	@	[\]	^	`	{		}	~				

* Not recommended for future use.

Glossary

To further aid you in the understanding of the printer and computer peripherals, we have created this glossary of terms. Some of the terms listed in this glossary appear in this User's Manual, while others are commonly used computer terminology.

A

Animate

This refers to a printer icon used when the **Printer Status Display** is an active window. If Animate is selected, the **Printer Status Display** will show paper feeding into and out of the printer.

Application

A program that you use to perform a specific task on your computer. These include programs for word-processing or graphics creation.

ATM fonts

An abbreviation for **Adobe Type Manager**. This font system was developed by *Adobe Systems*.

Attribute

The characteristics of a font. It includes orientation, symbol set, spacing, pitch, point size, style, stroke and typeface.

B

Backup

To make a copy of the original floppy diskette or a file on the hard disk. Making a backup of your disks or files ensures that you won't lose data if the originals are lost or damaged.

Bit

Binary digit. This is the smallest unit of information that a computer can hold. The value of a bit (which is either 1 or 0) represents a two-way choice (on or off, true or false, black or white).

Bitmap

A set of bits that represent a graphic image.

Bitmapped character

A character in a font that's rendered as a bitmap and drawn as a pixel pattern on the screen. See also **font** and **pixel**.

Bitmapped font

A font in a single point size made up of bitmapped characters. Some fonts stored in the computer system are bitmapped fonts.

Buffer

A "holding area" in the memory where information can be stored by one program or device and then read by another. For example, some printers have built-in memory to store text that comes from the computer faster than it can printed. This memory, which frees the computer for other work while the printer is printing is called a *printer buffer*.

Button

An image on your screen which resembles a push-button. You can click to designate, confirm or cancel an action.

Byte

A series of 8 bits that represent one character.

C

Cancel button

A button that appears in most dialog boxes which you can use to cancel any command or option you may have chosen.

Central processing unit (CPU)

The brain of the computer. It is the micro-processor which performs the actual computations.

Centronics parallel port

A standard wiring configuration for paral-

lel data transmission. Centronics is often used as a synonym for the parallel standard developed by Centronics Inc.

Character set

The complete set of characters available in a font.

Checkbox

A small box associated with an option in a dialog box or window. You can click on the checkbox to turn the option on or off. An option is on when there is an X in the checkbox.

Click

To position the pointer arrow on an object on your display and to press the left button of your mouse.

Command

An instruction that causes the computer to perform some action.

Configuration

(1) Your computer set up. (2) Your hardware: the computer, displays, keyboard and peripheral devices.

CPI

An abbreviation for Characters Per Inch.

D

Data bits

The number of bits in a transmitted byte that actually contains data.

Default

A preset value or setting on your computer which you can change.

Dialog box

A box which contains a message or instructions for you to follow or a box containing options from which you can select.

Document

Whatever you created on your computer using an application program.

Double-click

To position your pointer arrow on an object, such as an icon, and to press the left mouse button twice in quick succession without moving your mouse.

Drag and drop

To position your pointer arrow on an object and press and hold the left mouse button, moving the mouse and releasing the button.

Duplex Printing

Printing on both sides of the page.

E

EEPROM

Electronically Erasable Programmable Read Only Memory. It has an internal switch to permit the user to erase the contents and write new contents into it by means of electrical signals.

EET

An abbreviation for **Edge Enhancement Technology**. It is a smoothing technique developed by *Destiny Technology*.

EPS

An abbreviation of *Encapsulated PostScript*.

Engine

This is the mechanical printer developer and laser portion of the printer.

EP Cartridge (electrophotographic cartridge)

A type of process cartridge which contains the photosensitive drum and toner. Also called a **toner cartridge**.

Emulation

One printer's imitation of the functions of another printer.

Expansion RAM board

An available option that is easily attached to the computer to increase memory.

F

File

A named, ordered collection of information stored on your hard disk or floppy disk.

File menu

A menu that lists commands that affect your documents. File menus typically contain commands such as Save, Print and Quit.

Floppy disk

A disk made of flexible plastic which stores information from your computer. Floppy disks come in two types: 3.5" and 5.25."

Font

A set of letters, numbers or symbols of the same typeface design.

G

GDI

An abbreviation for Graphics Device Interface.

H

Handshaking

In data communications, the automatic acknowledgment by the receiving device of information that has been sent to it, either by signals and the interface ("hard") or by software controls ("soft").

Hex dump

Conversion by the printer of ASCII symbols into their hexadecimal (base 16) equivalent. This is useful for programmers or other users who want to troubleshoot the communications between the computer and the printer.

I

Icon

A small pictorial representation of an item on your computer's desktop in Windows.

Interface

A hardware plug that allows cable connections of two devices. For example, a cable from a computer parallel port to a printer's

parallel port.

L

Landscape

Printing on paper across its wider dimensions, such as a spreadsheet that is 11 inches wide and 8.5 inches high; landscape pictures are usually wider than they are tall.

M

Megabyte

1024 kilobytes, or 1,048,576 bytes. Also represented as **MB**.

Memory

Part of the computer system that can store information and retrieve it later.

Menu

A list of items either in the group windows or in your applications from which you can select. These are selected by clicking on them with your mouse button.

Mouse

A device that controls the pointer arrow on your display in Windows.

Mouse button

The button on the top of the mouse which you press to make selections or do some action on your screen.

MS-DOS

Microsoft Disk Operating System.

O

Output

Information which is transferred from your computer to an external device such as your screen, a disk, printer or modem.

P

Parallel

A communications interface that sends or receives 8 bits of information plus control signals at a time.

Parity

A bit in a serial information that allows a computer and printer to automatically check for errors in transmission.

PCL

An abbreviation for Printer Command Language.

Point

This is the typical unit of measurement for height of a font. One point equals 1/72nd inch.

Portrait

Printing on paper across the narrower dimensions, such as a letter on paper which is 8.5 inches wide and 11 inches high; portrait pictures are usually taller than they are wide.

PostScript

PostScript is a printer page description language developed by *Adobe Systems* to communicate between software applications and printers, independent of the printer's resolution.

Q

Queue

A list of jobs to be printed.

R

RAM

Random Access Memory. This is memory that can be used to store information temporarily such as text or printing configurations. RAM-stored information is erased when the power is turned off.

ROM

Read Only Memory. This is memory which can be stored permanently whether the power to the computer is on or off.

S

Scalable fonts

These are fonts created within the printer

on a character-by character basis ensuring high speed and print quality. In virtually limitless sizes, these fonts can be scaled from 3 points to 999.75 points in quarter-point increments.

Serial

A communications interface that sends or receives 1 bit of information at a time at a specified baud rate.

System fonts

These are fonts that are installed and used by Windows during a normal installation.

T

Title bar

The bar at the top of your window that shows the name of the current window.

TrueType font

A type of scalable font supplied with the Star WinType 4000 printer and used in Windows to create WYSIWYG (What You See Is What You Get) output. This font system was developed by Apple Computer.

V

Virtual memory

A method by which Windows substitutes hard disk space in place of RAM.

W

Window

An area of your display which shows information on your desktop. You can create and view documents through windows.

Windows

A graphical user interface software program developed by Microsoft Corporation for use on MS-DOS computers.

WYSIWYG

An abbreviation for What You See Is What You Get.

Index

Symbols

.PIF File Method	35, 38	Duplex printing	62
386 Enhanced	18	Duplex printing errors	30

A		E	
About	48, 62	Eliminating screen fonts	
Add	51	from your application	31
Animate Icon	61	Enhanced Mode	17
B		EP (electrophotographic) cartridge	2
Backup copy	20	EP (Toner) cartridge missing	63
Beep on Printer Error	28	Error LED	67, 74
Beep When Print Job is Complete	58	Errors when printing	57
Book Style	29	Exiting before a print	
		job has been completed	55

C		F	
Cable problem	63	Features of the printer	
CANCEL	55	driver software	26
Centronics parallel	5	Fonts in PCL Mode	39
Centronics parallel cable	12, 17	Fonts in PostScript Mode	33
Changing priority in the queue	50	Fonts in the Windows	
Character tables for PCL mode	79	Direct (GDI) mode	30
Cleaning the output port window	66	Format	49
Cleaning your printer	66	Front cover	2
Clearing paper jams	67	Front cover will not shut	74
Color monitor	49	Fuser	69
Configuration	23	Fuser Abnormality	63
Connect Port	47	Fuser area	67
Connecting the power cord	6	G	
Connecting the printer		GDI	25
to the computer	5	Glossary	83
Contents	48, 62	Guidelines for storing	12
Control Panel	18, 23, 32, 36, 57	H	
Copies	27	Handling of the toner cartridge	65
Cover Open	62	Help	48

D		I	
DELETE	50	IBM compatible PC	12, 17
Directory	21	Installing the printer driver	17
Display of information	49	Installing the printer driver software	20
Display print status	47		
Display Status While Printing	58		
DOS	26		
DOS command line	26		
DOS Prompt Method	35, 37		

Installing the toner cartridge	2	Paper Jam	62
Intellifont	30	Paper jams	27, 30
Interface cable	5	Paper out	62
Interface port	5	Paper release lever	7, 12, 14, 15, 16
		Paper size	27
J		Parallel interface cable	2
Job Name	49	Parallel Port	21
Job Name & Page No.	62	Parallel port	21
		Pause	50, 64
L		PCL	18, 25
Labels	12	PCL emulation	25
Landscape	27	PCL mode	25
Loading OHP (overhead projection) film label sheet	15	Permanent virtual memory	18
Loading paper	12	Picture of your printer	62
Locking knobs	3	Placing the printer	1
Low	46	Portrait	27
LPT1	47	PostScript	18, 25
LPT2	21, 47	PostScript language format	33
LPT3	21, 47	PostScript mode	25, 32
		<i>See also PCL mode:</i>	
M		Power cable	1
Main	26, 32, 36, 43, 57	Power cord	66
Maintaining your printer	65	Power Off	63
Maintenance & troubleshooting	65	Power Saving Mode	47
Manual duplex printing	29	Print Instruction Page	28
Medium	46	Print Manager	21
Memory	12, 17	Print manager	26, 43, 50
Minimum	48	Print status menu	57
Monochrome monitor	49	Print Status Window	47
MS-DOS command	25	Printer command languages	18
		Printer driver	17
		Printer driver software	1
		Printer error	
N		<i>See Printer Error: Beeps</i>	
Normal	48	Printers icon	26, 32, 36, 43, 57
NV-RAM Error	63	Printers window	23
		Printing DOS applications	
O		in PCL mode under Window	37
Options	27, 45, 61	Printing DOS applications in	
Options button	58	PostScript mode under Windows	35
Orientation	27	Printing from a DOS application	
Other mechanical problems	74	within Windows	37
Output port window	67	Printing from a Windows application	32
output tray	5	Printing in PCL mode from	
		a Windows application	36
P		Printing media to avoid	12
Package contents	1	Printing status information	26
Paper guides	13, 14, 15	Printing status options	58
		Printing to a file in the Windows	

Direct (GDI) and PCL modes	51	Solving print quality problems	70
Printing to an Encapsulated PostScript file in the PostScript mode	54	Specifications	75
Printing with the PCL mode	36	Star Micronics Bulletin Board Service	90
Printing with the Windows Direct (GDI) mode	26	Status Bar	50
Printing with the WinType 4000	25	Status Display Messages	62
Priority	46	System requirements	12, 17
Program Manager	20, 24, 26, 32, 36, 43, 57	T	
Progress Bar	50	Temporary	18
Q		Time	49
Quality printing	12	Time Format	47
Queue information	49	Toner cartridge	1, 65, 66, 68, 69
Quitting the print manager	55	Toner save mode	66
R		Toner Saving Mode	47
RAM	12, 17	Total memory	17
Recommended print media	11	Troubleshooting	70
Recovering from an error message in PCL or PostScript modes	40	TrueType	30
Reference information	75	TrueType fonts	78
Relocating the printer	7	Turning the printer OFF	6
Removing the printer driver software	24	Turning the printer ON	6
Report Style	29	Type 1	30
Restart Windows	22	U	
Resume	50, 62, 64	Unpacking and checking the package contents	1
Run	20	upper paper tray	4
S		Use WinType Print Manager	27
Saving download fonts and macros in the PCL mode	41	Using fonts in the GDI mode	30
Scanner Abnormality	63	V	
Search for Help On...	48, 62	Virtual Memory	18
Selecting print media	11	W	
Selecting the Printer Status Display - PCL and PostScript modes	59	Warming Up	62
Selecting the Printer Status Display - Windows Direct (GDI) mode	57	What You See Is What You Get	30
Setting up the output tray	5	Windows	17, 22
Setting up the upper paper tray	4	Windows application	26
Setting up your printer	1	Windows Direct (GDI) mode	25
Setup	20, 21, 22, 27	WinType Delete	24
Setup button	57	WinType GDI	26
Size	48, 49	WinType PostScript on WSPS	32
Smoothing On	47	WinType PostScript on WTPS	36
		WinType Print Manager	22
		WinType Printer Status Display	57
		WinType TEST	22
		WinType TEST Utility	23
		WinType Tool	22

Customer service information

In the event that you are experiencing some technical difficulty with your Star printer, please refer to Chapter 7 Maintenance & troubleshooting. That chapter provides you with easy methods to diagnose and resolve problems which you may encounter.

For further technical support, you should first contact your Authorized Star Dealer. If you require additional support, Star Micronics offers a wide variety of technical support services. Please use the phone numbers listed below based on the country which your Star printer was purchased.

Star Micronics Technical Hotline:

Hong Kong:	852-795-2335
Australia:	61-2-748-4300
New Zealand:	64-9-570-1470

Star Micronics Bulletin Board Service:

Requires a computer modem

United Kingdom:	44-494-461395
France:	33-1-305807
Germany:	49-69-780929
Netherlands:	31-73-424485
Australia and New Zealand:	61-2-748-2960

Customer response

Star Micronics Co., Ltd., invites your suggestions and comments on your printer and this Users Manual. Please address your correspondence to: Attn: Product Manager

Worldwide Headquarters

STAR MICRONICS CO., LTD.
536 Nanatsushinya, Shimizu
Shizuoka, 424 Japan

U.K. Market

STAR MICRONICS UK., LTD.
Star House
Peregrine Business Park
Gomm Road, High Wycombe
Bucks. HP13 7DL, U.K.

Australian Markets

STAR MICRONICS PTY, LTD.
Unit A/107-115 Asquith Street
Silverwater, NSW 2141
Australia

New Zealand Market

STAR MICRONICS (N.Z.) LTD.
64 Lunn Ave., Mount Wellington
P.O. Box 6255, Wellesly St.
Auckland, New Zealand

European Market

STAR MICRONICS DEUTSCHLAND GMBH
Westerbachstraße 59
D-60489 Frankfurt
F.R. of Germany

Asian Market

STAR MICRONICS ASIA LTD.
18/F Tower 2, Enterprise Square
9 Sheung Yuet Road, Kowloon Bay,
HONG KONG

PRINTED IN JAPAN